

Operation Manual



ZGR VERSATILE 10 - 20 KVA Online Three-phase UPS

INDEX

1	PRECAUTIONS	3
1.1	General precautions	3
1.2	Storage precautions	4
1.3	Environmental precautions	5
1.4	Precautions during transportation	5
1.5	Precautions during transportation	6
1.6	Symbols used in this manual	6
2	GENERAL DESCRIPTION	7
2.1	Introduction	7
2.2	Main characteristics	7
2.3	Construction of ZGR VERSATILE 10 - 20 KVA	8
3	ZGR VERSATILE 10 - 20 KVA OPERATION	8
3.1	Operation Modes	8
3.1.1	Normal mode	9
3.1.2	Battery mode (Stored Energy Mode)	9
3.1.3	Bypass mode	9
3.1.4	ECO Mode	9
3.1.5	Parallel redundancy mode (system expansion)	10
3.2	Working Mode and transferring	10
3.2.1	Transfer to bypass if overload	10
3.2.2	Normal mode to battery mode	10
3.2.3	Go to bypass mode due to over temperature	10
3.2.4	Output short circuit	10
3.2.5	Battery self-Test	11
3.3	Turn on/off UPS	11
3.3.1	Connecting with Utility	11
3.3.2	Black (Cold) start procedure	12
3.3.3	Inverter Off	12
3.3.4	Disconnecting with Utility	12
4	CONTROL PANEL AND MONITORIZATION	13
4.1.1	LCD control panel	13
4.1.2	Control panel menu	13
4.1.3	Control panel interfaces	13
4.1.4	Status and operation modes	19
4.2	Events and status list	19
5	INSTALLATION	21
5.1	Receiving the material	21
5.2	Mechanical installation	21
5.3	Electrical installation	22
5.3.1	External battery connection	22
5.3.2	UPS input and output connection	22
5.4	UPS in parallel	23
5.4.1	Parallel cabinet installation	24

5.4.2	Parallel cable installation	25
5.4.3	Initial startup procedure for parallel system	25
6	COMMUNICATIONS	26
6.1.1	USB communication port definition	26
6.2	Intelligent slot	26
6.2.1	TCP-IP communications card (optional)	27
6.2.2	Dry-contact relay card (optional)	28
6.3	UPS remote access	28
6.3.1	IP manual assignment	29
6.3.2	NetAgent webserver main screen	29
7	TROUBLESHOOTING	31
7.1	Malfunctions of ZGR VERSATILE 10 - 20 KVA	31
8	MAINTENANCE	32
8.1	Battery maintenance	33
9	TECHNICAL SPECIFICATIONS	34
10	STANDARDS	36
11	WARRANTY	37

© 2024, ZIGOR

All rights reserved. The total or partial reproduction of this User Manual, or its transmission of any type or by any means, be this mechanical or electronic, by means of photocopies, registration or other information storage or recovery procedure, without the permission of the editor, is totally forbidden.

The contents of this manual are exact at the time it was printed. However, with the intention of complying with our aim of continuous development and improvement, the manufacturer reserves the right to change the specifications of the product, its operation or the contents of the Operating Manual without prior warning.

1 PRECAUTIONS

1.1 General precautions

For your own safety and that of the unit, you must read and understand the instructions contained in this document before starting work.

Keep these instructions in a place accessible to all the personnel who work with the unit so that they can be consulted.

Only expert and duly authorised personnel may operate our units.



Danger warnings. When handling or accessing the interior of the ZGR VERSATILE 10 - 20 KVA, please remember that some parts may be live. Pay special attention to soldering points, printed circuits, connecting terminals, relay contacts, etc. Before opening the equipment, disconnect the voltage of all poles (both alternating and direct) and wait at least 5 minutes for the internal condensers to discharge.

Arbitrary modifications are forbidden. The unit must not be subjected to any modification regarding its construction or safety without ZIGOR's **express consent**. **Any modification will free** ZIGOR of any responsibility for any damage caused as a result of the modification. In particular, all repair work, soldering of printed circuit boards and replacing of components, modules and printed circuit boards, without the express authorisation of ZIGOR, is forbidden. Should spare parts be used, only ZIGOR original parts shall be utilised.

Use the unit for the purpose for which it was designed. The system supplied must be used only for the purpose for which it was designed. Any other use is strictly forbidden. ZIGOR cannot accept responsibility for any damage that might result from its use for any other purpose. In such cases, the user shall assume exclusive responsibility for any risk. The use for which the unit was designed is defined in the documentation. The system shall be exposed only to admissible environmental conditions. These are defined in the technical details provided for the equipment.

ZIGOR accepts no responsibility for any inadequate, negligent or incorrect installation of the equipment.



This supply equipment contains a lethal voltage. Comply with the instructions set out in this manual to avoid any risk of electrical shock.

Please follow the indications set out below to operate under conditions of complete safety:

- The System must be checked once the installation has been completed by a qualified technician and before being put into operation. Should these indications not be adhered to, the warranty shall be considered null and void.
- These units do not contain parts usable for other purposes by the user.
- Do not power up the device before a technician has checked it.
- Given the risk of electric shock or burns, do not try to open the device.
- Work inside the cabinet should be undertaken only by qualified personnel who are familiar with the safety measures to be applied and the specific technical characteristics of the unit.
- The unit does not contain any user repairable or replaceable elements. In the case of any malfunction or problems operating the unit, please contact ZIGOR.
- Do not place the system near power magnets as this might cause a malfunction.
- Do not block or cover the ventilation grills in the housing.
- The ZGR VERSATILE 10 - 20 KVA is designed in accordance with current Spanish legislation. Check these regulations against those corresponding to the country in which the unit is to be installed and against the most restrictive regulations of the electricity supplier.
- All user controls are accessible from the exterior.
- Should you have any problems with the contents of this manual, you must ask ZIGOR for assistance.

- This system has been designed for industrial use and not for domestic-commercial use.
- Even though all the safety systems are in place, before touching any working parts, you must check that they are not live.
- If any liquid is spilt accidentally on the System, disconnect it and call to ZIGOR support.
- During assembly work, start-up or maintenance, wear goggles to avoid any damage to your eyes due to accidental electric arcing.
- Use only insulated tools.
- The unit must be protected against rain and excess humidity and installed in a clean atmosphere, without inflammable liquids, gases or oxidising substances.
- The battery may pose a risk of electric shock or burns due to its high short circuit current.
- If the batteries lose electrolyte or are physically damaged, they must be placed in a container in resistant to corrosive liquids (acids or alkaline according to the type of battery) and prepared in accordance with local regulations.
- If the electrolyte comes into contact with the skin, the affected area must be washed immediately with clean water.
- For the sake of human being safety, please well earth the UPS before starting it.
- Do not throw batteries into a fire as they may explode.
- UPS models with internal batteries can be powered even when the UPS input is not connected to the mains.
- Do not disconnect the input from the UPS and make sure the UPS is completely off before moving it or reconfiguring the connection; otherwise, there is a risk of electric shock.
- Please contact and discuss with ZIGOR before connecting the UPS to following equipments
 - **Medical equipments which have direct relationship with patients' life**
 - Equipments like elevators which may do harm to human beings
 - Similar equipments as mentioned above
- Only authorized personnel should repair or install the batteries.

1.2 Storage precautions

The store where the material is kept must protect the material from the elements, risk of flooding or contact with water.

The material shall be protected from any risk of overheating due to exposure to direct sunlight or through windows.

The recommended storage temperature of UPS with internal battery is $-20\text{ }^{\circ}\text{C}$ to $+55\text{ }^{\circ}\text{C}$, and extended backup model without internal battery is $-40\text{ }^{\circ}\text{C}$ to $+70\text{ }^{\circ}\text{C}$. An increase of $10\text{ }^{\circ}\text{C}$ can reduce the service life of the battery by 50%. The recommended relative humidity is from 5% to 95%.

When the UPS or batteries are stored, it is recommended to connect them to the network for at least 12 hours every 3 months to prevent the battery from draining excessively.

To avoid any risk of mechanical shock, do not stack the packages. These must be placed in accordance with the silkscreen printed details on the boxes used for packaging.



WARNING

Any failure to respect these precautions may render the product warranty null and void.

1.3 Environmental precautions



Dispose of the packaging in an ecological way: ZIGOR, based on the exceptions detailed in the First Additional Provision of Law 11/1997 on commercial or industrial packaging, informs that the final holder of the waste of used containers and packaging, as responsible for them, you must deliver them in appropriate conditions for reuse, to an authorized recuperator, recycler or re-valuer.

The subsets of the system are recyclable products and cannot be treated as household / municipal waste at the end of its useful life.

To preserve the environment, manage them in accordance with current environmental regulations and requirements in each country or community. In case of doubt, consult the manufacturer.



Correct product disposal: This electrical-electronic device (AEE) is marked with the symbol of compliance with the European Directive 2012/19 / EU (WEEE) regarding used electrical and electronic equipment (Waste electrical and electronic equipment WEEE, RD 110/2015).

The Directive provides the general framework valid throughout the European Union for the removal and reuse of waste from EEE.

To dispose of this product and ensure its proper management, follow the current local environmental legislation and regulations. In this way it will contribute to conserve the environment.

Correct disposal of batteries: Used batteries are reusable consumer products and a recycling process must be carried out.

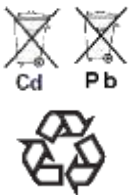

Used batteries that do not go through the recycling process must be disposed of according to the instructions regarding special waste, in accordance with the regulations and environmental requirements in force in each country or community. This requirement applies in the European Union and in those places where separate collection systems are available.

In case of doubt, consult the manufacturer.

In this way it will contribute to conserve the environment.

1.4 Precautions during transportation

Please transport the UPS system only in the original package to protect against shock and impact. The procedure to transport of the UPS to the final location should follow the procedure:

1. Use a pallet truck to transport the UPS to the installation position.
2. Check the UPS packing.
3. **Don't lean the UPS when moving it out from the packaging.**
4. Check the appearance to see if the UPS is damaged or not during the transportation, do not switch on the UPS if any damage found. Please contact the dealer right away.
5. Check the accessories according to the packing list and contact the dealer in case of missing parts.

1.5 Precautions during transportation

Visually check that the UPS location is adequate by checking its characteristics (clean, free of leaks with good ventilation); the floor must be level and have sufficient load resistance for the equipment.

Checking the material

Do not lean the UPS when moving it out from the packaging.

On receiving the material, a visual inspection should be made in order to detect any anomalies that may have occurred during transport.

List and check all the items indicated on the delivery note. Should any component be missing, notify the forwarding agent within the established deadline.

Extract all parts from the packaging and examine the unit for any damage caused during transport.

Report any damage to the forwarding agent and ZIGOR.

Check that the material delivered corresponds to the delivery note. Check the manufacturer's label placed at the rear or on one side of the unit.

Responsibility for the loss or damage of products shall transfer to the Customer from the moment ZIGOR, places these at his disposal in the place indicated by the Customer.

From then on, the customer will have 24 hours to make any claim under guarantee for any anomaly in the amount or quality of the products received, providing details of the material received in bad condition after reporting this circumstance on the forwarding agent's delivery note on reception.

Should the customer not report any defect within 24 hours, it will be understood that he has accepted delivery of the unit.

1.6 Symbols used in this manual

The symbols of security that are used in this manual are showed in the following Table 1-1; these symbols are used to inform to the costumers about the security questions must be follow during the installation, the operation and the maintenance



SECURITY SYMBOL	INDICATION
	Attention
	Sensitive to electric shock
	Risk of electric shock

Table 1-1 Symbols meaning

2 GENERAL DESCRIPTION

2.1 Introduction

ZGR VERSATILE 10 - 20 KVA is a transformer-less UPS, in tower format and available in 10 - 15 - 20 kVA models with three-phase / single-phase input and single-phase output.

ZGR VERSATILE 10 - 20 KVA incorporates the most advanced technologies in DSP (digital signal processor), three-level inverter and maximum protection against critical loads, always optimizing energy savings.

This series anticipates the evolution from your single-phase installation to future needs for three-phase input grid. Extends the single-phase installation life reducing costs.

This series UPS, providing reliable AC power to various equipment, can be used for computer center, network management centre, auto control system, telecom systems, etc.

The UPS available range is as follows (Table 2-1):

MODEL	10 kVA	15 kVA	20 kVA
REMARKS	Extended model External battery	Extended model External battery	Extended model External battery

Table 2-1 Range of ZGR VERSATILE 10 - 20 KVA

2.2 Main characteristics

- Convertible 3:1 / 1:1
- Online double conversion with DSP control
- Power factor of 1.0
- Low input and output current distortion
- Efficiency up to 94 %
- Parallelable up to 4 units
- Active ECO function: Minimize UPS self-consumption and improves efficiency up to 98%
- Allows common battery in parallel mode
- **2,4" colour display and LED indicators**
- Compatible with generator sets
- Standard models are designed for external long autonomy battery
- Configurable battery charge voltage and current
- Configurable battery voltage (16, 18, 20 batteries , PF 0.8/0.9/1.0 respectively)
- Periodic battery test configurable
- Cold start and Auto Restart function

2.3 Construction of ZGR VERSATILE 10 - 20 KVA

Following, front and rear views of ZGR VERSATILE 10 - 20 KVA (Fig. 2-1 and Fig. 2-2):

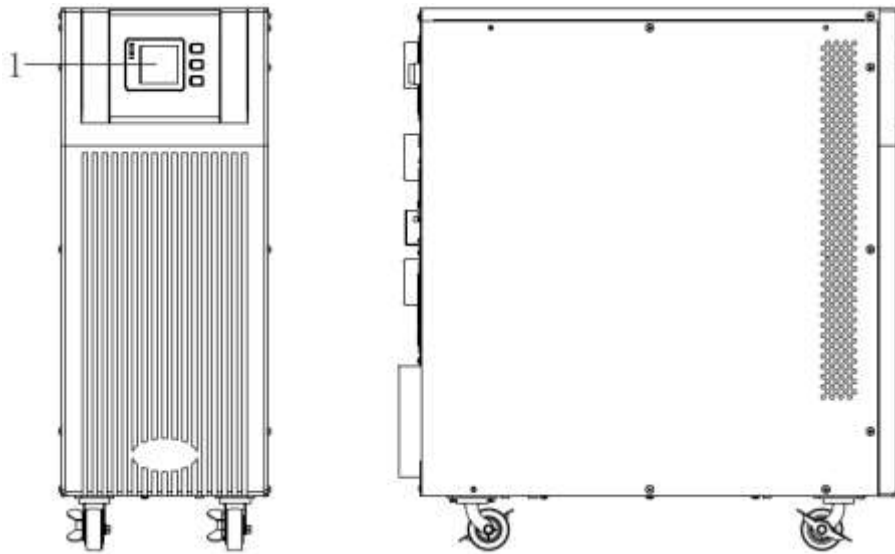

Fig. 2-1 Complete view 10/15/20k

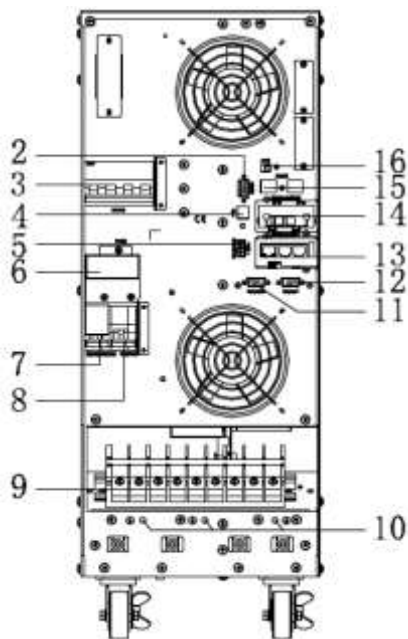

Fig. 2-2 Rear panel 10/15/20k

The elements and connections of the rear panel are:

1. Intelligent slot
2. Comm. Port RS232
3. Input switch
4. Comm. Port USB
5. Built-In dry contact alarm
6. Maintenance switch cover
7. Maintenance switch
8. Output switch
9. Input/Output/Battery terminals
10. Ground terminals
11. Parallel port 1
12. Parallel port 2
13. Intelligent slot 1 (SNMP / Dry contact)
14. Intelligent slot 2 (SNMP / Dry contact)
15. Comm. Port RS485
16. Emergency Power Off input (EPO)

3 ZGR VERSATILE 10 - 20 KVA OPERATION

3.1 Operation Modes

ZGR VERSATILE 10 - 20 KVA is a double-conversion on-line UPS that may operate in the following alternative modes:

3.1.1 Normal mode

The rectifier/charger derives power from the AC mains and supplies DC power to the inverter while floating and boosting charge the battery simultaneously. Then, the inverter converts the DC power to AC and supplies to the load (Fig. 3-1).

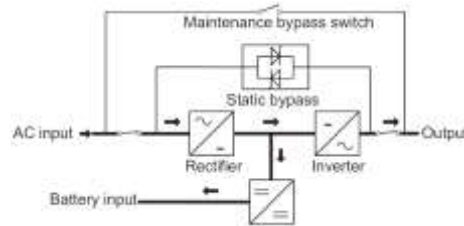

Fig. 3-1 Normal mode

3.1.2 Battery mode (Stored Energy Mode)

If the AC mains input power fails, the inverter, which obtains power from the battery, supplies the critical AC load. There is no power interruption to the critical load. The UPS will automatically return to Normal Mode when AC supply recovers (Fig. 3-2).

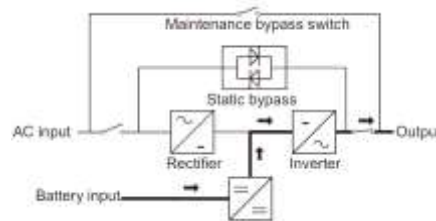

Fig. 3-2 Battery mode

3.1.3 Bypass mode

If the inverter is out of order, or if overload occurs, the static transfer switch will be activated to transfer the load from the inverter supply to bypass supply without interruption to the critical load (Fig. 3-3).

In the event that the inverter output is not synchronized with the bypass AC source, the static switch will perform a transfer of the load from the inverter to the bypass with power interruption to the critical AC load. This is to avoid paralleling of unsynchronized AC sources. This interruption is programmable but typically set to be less than an electrical cycle e.g. less than 15 ms (50 Hz) or less than 13,33 ms (60 Hz).

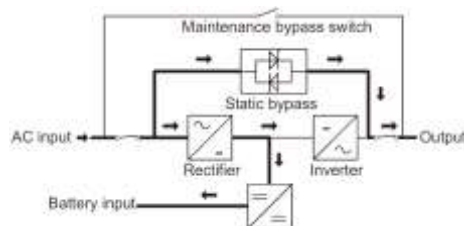

Fig. 3-3 Bypass mode



WARNING

Due to this UPS system is based on 3phase input and 1phase output, in case of failure and bypass transfer, total load energy will go through phase 1 (A), so the wiring and protections must be sized properly.

3.1.4 ECO Mode

When the UPS is at AC Mode and the requirement to the load is not critical, the UPS can be set at ECO mode in

order to increase the efficiency of the power supplied. At ECO mode, the UPS works at Line-interactive mode, so the UPS will transfer to bypass supply (Fig. 3-4).

When the AC is out of set window, the UPS will transfer from bypass to Inverter and supplies power from the battery, and the LCD will show all related information on the screen.

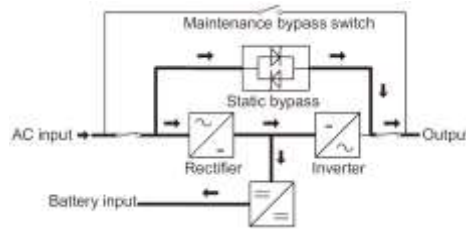

Fig. 3-4 ECO mode

3.1.5 Parallel redundancy mode (system expansion)

To achieve a higher capacity and / or increase reliability, the outputs of up to four UPS modules can be programmed to operate in parallel. The built-in parallel controller in each UPS ensures automatic load sharing.

3.2 Working Mode and transferring

Usually, the UPS should be set to work in AC mode, so it will transfer to battery mode automatically without interruption when AC fails. When the UPS is overloaded, it will transfer to bypass mode without interruption. When the inverter is defective or over temperature occurred inside the UPS, the UPS will transfer to bypass mode if the bypass is normal.

3.2.1 Transfer to bypass if overload

When the load of UPS is beyond normal range and lasts for the time set, it will transfer to bypass mode and beeps twice every second, and then the load is powered by AC directly. Please decrease the load immediately until the alarm is eliminated. The UPS will start the inverter after 5 minutes.

In order to protect the load and the UPS, it is required to set the limitation times of transferring to bypass mode due to overload in 1 hour. If it exceeds the limitation times set, the UPS will keep in bypass mode.

3.2.2 Normal mode to battery mode

The UPS will go to battery mode if the AC is failed. The UPS will shut down automatically if batteries are drained. When AC recovers, the UPS will start the inverter automatically.

3.2.3 Go to bypass mode due to over temperature

The temperature inside UPS may be high if ambient temperature is high or the ventilation is poor, then the UPS will go to Bypass mode, fault indicator will be on (red), the LCD will display that the inner temperature is high, long beeps will come.

If so, please cut off the input power of the UPS, move objects that affecting the ventilation far from the UPS if any or increase the distance between the UPS and the wall. Wait until the UPS temperature becomes normal then restart it.

3.2.4 Output short circuit

When the UPS output is in short circuit, the UPS will cut off the output, fault indicator will be on (red), the LCD will display output is in short circuit, long beeps come.

If so, please disconnect the load in short circuit, cut off the UPS input power and wait for 10mins, the UPS will shut down automatically or press the off button to shut down in after 10s. Before restarting the UPS, please make sure that the short circuit problem has been solved.

3.2.5 Battery self-Test

The default Settings is “OFF” when the UPS has no need of the battery self-test function. When turn to “ON”, batteries can do the self-test automatically per 30 days. Three kinds of Battery Self-test Time can be chose as below.

1. When choosing 10 s, UPS can transfer to Battery Mode automatically per 30 days. And the Battery Self-test Time is 10 seconds.
2. When choosing 10 m, UPS can transfer to Battery Mode automatically per 30 days. And the Battery Self-test Time is 10 minutes.
3. When choosing EOD UPS can transfer to Battery Mode automatically per 30 days. And the Battery Self-test Time is EOD.

3.3 Turn on/off UPS

3.3.1 Connecting with Utility



PRECAUTION

Make sure grounding is properly done.

- Set the Battery Breaker to the “ON” position according to the user's manual.
- Switch on the UPS



PRECAUTION

Check to see if the load is safely connected with the output of the UPS. If the load is not ready to receive power from the UPS, make sure that it is safely isolated from the UPS output terminals

The internal fan of the UPS starts spinning, the UPS is performing self-diagnostics until buzzer beeps twice to show the UPS is normal. Then, the UPS goes to bypass supply, Utility LED and Bypass LED turn green, the inverter is starting up now. When the inverter is checked “normal”, the UPS goes to working mode and the load is supplied by the inverter now.

No matter the UPS is operated normally or not, the LCD display will indicate current status. The top lines display the UPS operational status and the bottom lines indicate alarm conditions when they occur.

3.3.2 Black (Cold) start procedure

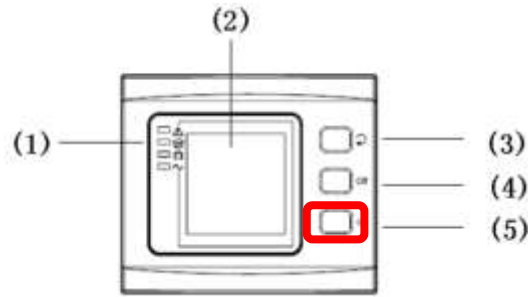

Fig. 3-5 Cold Start



PRECAUTION

Follow these procedures when the input AC Utility Failure, but battery is normal

- Turn on the battery switch.
- The battery will feed the Auxiliary power board.
- Press ON button for Cold Start (Fig. 3-5).

When battery normal, rectifier starts operation, 30 s later, inverter starts and operates, INV and output light up.



PRECAUTION

Wait for approximately 30 seconds before you press the black start key

3.3.3 Inverter Off

When the Utility is normal, press “ESC /OFF” button for approx. 1 sec until beep sounds, the inverter LED will extinguish, the bypass LED on, then the UPS turns to bypass supply.

When the UPS is on battery mode or without AC, press “ESC /OFF” button for approx. 1 sec until beep sounds, the output of the UPS is off, fan stop spinning. After 60 seconds, all the LED on the LCD display extinguish.

3.3.4 Disconnecting with Utility



PRECAUTION

This procedure should be followed to completely shut down the UPS and the LOAD. After all power switches, isolators and circuit breakers are opened, there will be no output.

After the inverter is off, turn the Utility and battery breakers to “OFF”, then the LCD display will extinguish completely and fan stops spinning in 60 seconds. If there are external battery packs connected, please also turn the battery breaker to “OFF”.



PRECAUTION

Wait for about 5 minutes for the internal D.C. bus bar capacitors to be completely discharged.

4 CONTROL PANEL AND MONITORIZATION

To get the UPS completely monitored by the software, you just simply connect RS232 or USB cable to each end of the computer and the UPS respectively.

4.1.1 LCD control panel

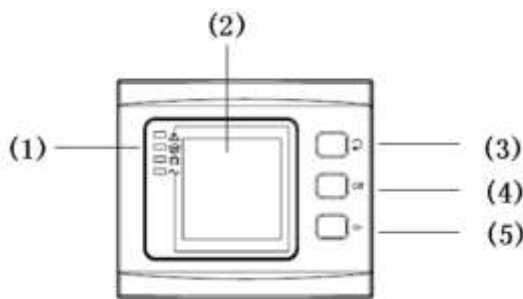

1. LED indicator
2. LCD Display Board
3. Scroll button
4. OFF button
5. ON button

Fig. 4-1 LCD control panel

NOTE: Key ROTATE (⤵): Press for 10 seconds to rotate LCD.

4.1.2 Control panel menu

1 Main menu switching

Pressing the left/right arrow and ENT button can switch among alarm info, running parameter and function settings. Press ENT to enter alarm info, running parameters or function settings. To enter function settings, double pressing on ENT is required.

2 Submenu switching

- 1) Press the arrow button can view the details after entering the running function interface, and press ESC to return to main menu.
- 2) Press the arrow button can view the details after entering the function settings interface, press the ESC to return to main menu
- 3) Parameter which has been selected and changed will be highlighted. Press arrow button to change the value and press ENT to confirm it. Once confirmed, it will not be highlighted.
- 4) Press the arrow button can view the detailed alarm info after entering the alarm info interface, press the ESC to return to main menu

3 Priority of info displayed on LCD

- 1) If there is alarm but no valid operation on buttons, the alarm info with top priority will be shown on LCD automatically
- 2) **When there isn't any alarm and the LCD is displaying the submenu of running parameters, such as output current, these parameters will be always displayed on the LCD if no further operation on buttons. If the LCD is not displaying the submenu of running parameters, it will return to main menu in 30s as long as there isn't any operation on buttons**

4.1.3 Control panel interfaces

- 1) MAIN: The main interface below comes out when the power is connected or the system is cold start (Fig. 4-2). Shows UPS status graph.

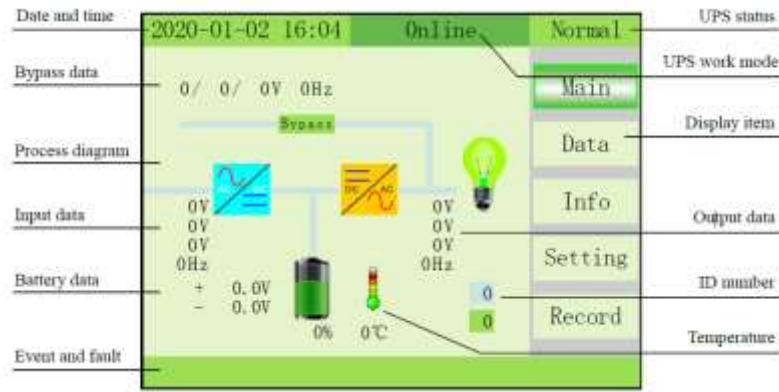

Fig. 4-2 Main interface

Press to scroll between menu options (Fig. 4-3).

Press for 2 sec to enter detailed information menu

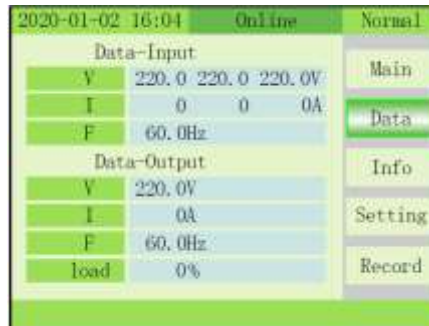

Fig. 4-3 Basic status interface

2) DATA: This menu shows input and output detailed information (Fig. 4-4).

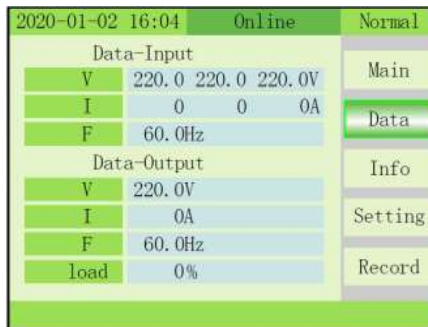



Fig. 4-4 Data menu

In this page is real time input data. Press button to roll between screens. Input/Output/Battery/Load/Inner temperature

3) OUTPUT: Press key for short time to move to the second page, the second page of Data is Output data. (Fig. 4-5).



Fig. 4-5 Output menu

- 4) BATTERY: Press  key for short time to move to the third page, the third page of data is Battery data. (Fig. 4-6).



2020-01-02 16:04		Online	Normal
Data-Battery			
V	+120	-120V	Input
I	0	0A	Output
Time	0	0min	Battery
CoP.	0	0%	Load
			Inside

Fig. 4-6 Data/Battery menu

- 5) LOAD: Press  key for short time to move to the fourth page, the fourth page of data is Load data (Fig. 4-7).



2020-01-02 16:04		Online	Normal
Data-Load			
%	0	0	0%
P	0	0	0kW
S	0	0	0kVA
			Input
			Output
			Battery
			Load
			Inside

Fig. 4-7 Data/Load menu

- 6) INSIDE: Press  key for short time to move to the fifth page, the fifth page of data is Inside data.
- 7) INFO: Press  key for long time to exit Data, and press  key for short time move to Info, this page displays the version of the LCD/LED, DSP and the UPS type. (Fig. 4-8).

2020-01-02 16:04		Online	Normal
Information			
LCD Ver.	V004B001D000		Main
FFC Ver.	V001B345D000		Data
INV Ver.	V001B345D000		Info
Power	10.0kVA		Setting
			Record

Fig. 4-8 Info menu

- 8) SETTING-User: Press  key for short time to move to the setting page, then press OFF key (Fig. 4-9) to enter setting-user page. Press  key to change item, press OFF key to enter item and press  key to change value, press OFF key confirm the setting.

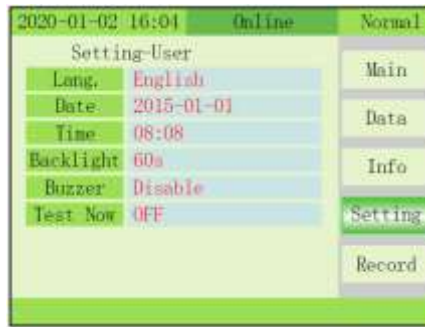



Fig. 4-9 Setting menu

Press OFF key to enter test now Test Now, press  to select test value and press OFF to confirm. The Battery manual test command can test battery discharge for 10 s, 10 min and to End of Discharge EOD. (Fig. 4-10).

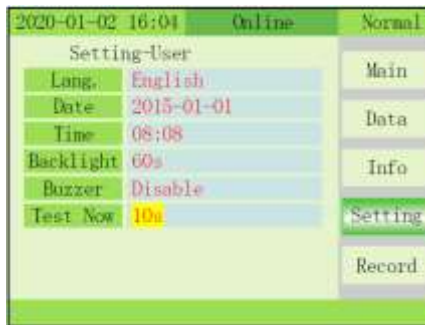



Fig. 4-10 Setting/Test Now menu

- 9) MAINTENANCE: Press  + OFF key to enter maintenance and display a password window. This setting is only accessible by authorized personal. Contact ZIGOR for training. (Fig. 4-11).



Fig. 4-11 Setting/Maintenance menu

- 10) MAINTENANCE – SYSTEM: Press OFF key to enter item and confirm value, press  change value (Fig. 4-12).

Work mode: Normal, Paralado, ECO

V_Output Grade: 220/230/240 V

F_Output Grade: 50 and 60 Hz

F_mode: CVCF and Non-CVCF (Fecueny converter)

Test type: 10 s, 10 min and EOD

Test Cycle: 1~30 days

Equipment ID: Device address is 1~15, it is the MODBUS device address used for RS232 & RS485 communication ports. ① Press  to set the address 1~15. When battery temperature sensor is open, choose 1~10 & 13~15; If it's parallel mode and device address <= parallel quantity, device address= parallel ID. ② Press "ON" to exit the device address setting and save the device address setting value and parallel ID setting. (Note: Under single UPS mode, until this device address setting save and exit, single UPS setting

is done.)

Temp. Sensor SW: ON or OFF. OFF means turn off the sensor switch, ON means turn on the sensor switch, send query command to sensor with address 11,12 every second.

2020-01-02 16:04 Parallel Normal	
Setting-System	
Work Mode	Parallel
V Output Grade	220V
F Output Grade	50Hz
F Mode	non-CVCF
Test Type	OFF
Test Circle	30 Day
EquipmentID	8
Temp. Sensor SW	OFF

Fig. 4-12 Setting/Maintenance - System menu

11) MAINTENANCE – BYPASS: Press OFF key to enter item and confirm value, press ↻ change value (Fig. 4-13).

This menu defines how the static bypass will work. This limits will will lock/unlock bypass transfer.

2020-01-02 16:04 Parallel Normal	
Setting-Bypass	
Upper Limit	20%
Lower Limit	-15%
F Range	1%

Fig. 4-13 Setting/Maintenance - Bypass menu

12) MAINTENANCE – BATTERY: Press OFF key to enter item and confirm value, press ↻ change value (Fig. 4-14).

Number: 16/18/20 PCS Total (Note: there are 8/9/10pcs between “Bat+ / BatN” string and “BatN / Bat-“ string)

Capacity: 7~2000Ah

Boost charge: Enable or disable

Group: 1~8

V-Boost: 2,30~2,40, step is 0.01V

V-Float: 2,20~2,29, step is 0.01VV-EOD:1,75V o 1,80V

I-Maxcharge: 1~10A

2020-01-02 16:04 Parallel Normal	
Setting-Battery	
Number	20 PCS
Capacity	65 Ah
Boost Charge	Enable
Group	1
V-Boost	2.30
V-Float	2.25
V-EOD	1.75
I-MaxCharge	9 A
INV Over Temperature	

Fig. 4-14 Setting/Maintenance – Battery menu

13) MAINTENANCE – PARALLEL: This item can be selected after the work mode is set to parallel. Press OFF

key to enter item and confirm value, press ↻ change value (Fig. 4-15).

ID: 1-4. UPS ID define parallel order.

Number: 1-4, UPS parallel max number.

Redu. Num: 1-3, redundancy UPS number.

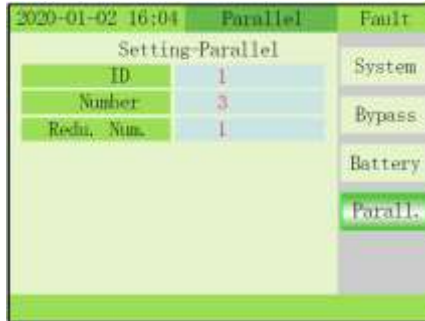

Fig. 4-15 Setting/Maintenance - Parallel menu

14) RECORD: Displays event records and fault records (Fig. 4-16).



Fig. 4-16 Record menu

15) RECORD-EVENT: Press ↻ to select Up or Down or Delete. Press OFF key to confirm (Fig. 4-17).



Fig. 4-17 Record - Events menu

16) RECORD-FAULTS: Press ↻ to select Up or Down or Delete. Press OFF key to confirm (Fig. 4-18).



Fig. 4-18 Record - Faults menu

4.1.4 Status and operation modes

This section lists the status messages and the operation modes that the UPS might display (Table 4-1).

N°	MESSAGE	LED			
		FAULT	BYPASS	BATTERY	INVERTER
1	Initialized	Off	Off	Off	Off
2	Standby mode	Off	Off	X	Off
3	No output	Off	Off	X	Off
4	Bypass mode	Off	On	X	Off
5	Utility mode	Off	Off	X	On
6	Battery mode	Off	Off	On	Off
7	Battery self-diagnostics	Off	Off	On	Off
8	Inverter is starting up	Off	X	X	Off
9	ECO mode	Off	X	X	X
10	EPO mode	On	Off	X	Off
11	Maintenance bypass mode	Off	Off	Off	Off
12	Fault mode	On	X	X	X

Table 4-1 Status and operation modes (“X” shows that it will determine by other conditions.)

4.2 Events and status list

When an alarm or event occurs in the equipment, it will be registered and will be showed in the control panel. Below a list of possible events of the system is described (Table 4-2):

ITEM	UPS ALARM WARNING	BUZZ	LED
1	Rectifier Fault	Beep continuously	Fault LED lit
2	Inverter fault	Beep continuously	Fault LED lit
3	Inverter Thyristor short	Beep continuously	Fault LED lit
4	Inverter Thyristor broken	Beep continuously	Fault LED lit
5	Bypass Thyristor short	Beep continuously	Fault LED lit
6	Bypass Thyristor broken	Beep continuously	Fault LED lit
7	Fuse broken (Reserved)	Beep continuously	Fault LED lit
8	Parallel relay fault	Beep continuously	Fault LED lit
9	Fan fault	Beep continuously	Fault LED lit
10	Reserved	Beep continuously	Fault LED lit
11	Auxiliary power fault	Beep continuously	Fault LED lit

12	Initialization fault	Beep continuously	Fault LED lit
13	P-Battery Charger fault	Beep continuously	Fault LED lit
14	N-Battery Charger fault	Beep continuously	Fault LED lit
15	DC Bus over voltage	Beep continuously	Fault LED lit
16	DC Bus below voltage	Beep continuously	Fault LED lit
17	DC bus unbalance	Beep continuously	Fault LED lit
18	Soft start failed	Beep continuously	Fault LED lit
19	Rectifier Over Temperature	Twice per second	Fault LED lit
20	Inverter Over temperature	Twice per second	Fault LED lit
21	Input N loss	Twice per second	Fault LED lit
22	Battery reverse	Twice per second	Fault LED lit
23	Cable connection error	Twice per second	Fault LED lit
24	CAN comm. Fault	Twice per second	Fault LED lit
25	Parallel load sharing fault	Twice per second	Fault LED lit
26	Battery over voltage	Once per second	Fault LED blinking
27	Mains volt. reverse (Reserved)	Once per second	Fault LED blinking
28	Bypass reverse (Reserved)	Once per second	Fault LED blinking
29	Output Short-circuit	Once per second	Fault LED blinking
30	Rectifier over current	Once per second	Fault LED blinking
31	Bypass over current	Once per second	BPS LED blinking
32	Overload	Once per second	INV or BPS blinking
33	No battery	Once per second	BATTERY blinking
34	Battery under voltage	Once per second	BATTERY blinking
35	Battery low pre-warning	Once per second	BATTERY blinking
36	Internal Communication Error	Once per second	Bypass LED lit
37	DC component over limit.	Once per 2 seconds	INV blinking
38	Parallel Overload	Once per 2 seconds	INV blinking
39	Mains volt. Abnormal	Once per 2 seconds	BATTERY LED lit
40	Mains freq. abnormal	Once per 2 seconds	BATTERY LED lit
41	Bypass Not Available		BPS blinking
42	Bypass unable to trace		BPS blinking
43	Boot is invalid		

Table 4-2 List of possible events of ZGR VERSATILE 10 - 20 KVA

5 INSTALLATION

5.1 Receiving the material

Don't lean the UPS when moving it out from the packaging.

Check the appearance to see if the UPS is damaged during transportation, do not switch on the UPS if any damaged is found and please contact the dealer.

Check the accessories according to the packing list and contact the dealer if any parts missing.

From then on, the customer will have 24 hours to make any claim under guarantee for any anomaly in the amount or quality of the products received, providing details of the material received in bad condition after reporting this circumstance on the forwarding agent's delivery note on reception.

Should the customer not report any defect within 24 hours, it will be understood that he has accepted delivery of the unit.

5.2 Mechanical installation



WARNING

Ensure that the weight of the unit is within the maximum load limits (kg) of the tools used in order to handle it and the supports used to secure it in place. Review weight details in the specifications of the ZGR VERSATILE 10 - 20 KVA.

- Put the UPS at flat place next to the equipment.
- Keep the UPS at least 20cm from wall or equipment or other object. **Don't block the ventilation holes** of the UPS located in the front panel and the bottom part, so as to keep the ventilation in good condition & avoid temperature of components inside getting high.
- Keep the UPS away from high temperature, water, flammable gas, corrosive gas, dust, direct sunlight and explosive things
- Don't lay the UPS outdoor.
- 3P 125 A / 400 V circuit breaker is required at the input and battery and 2P 125 A / 400 V is required at the output.
- PDU is required to connect to the UPS output so as to weaken the affection between loads
- In order to fix the UPS, please lock its wheels by shifting the sheet on each wheel.
- RCD load like computer, linear load and small inductive load can be connected with the UPS. Please contact dealer if other types of loads is required to be connected with.
- For the safety sake of user and equipments, please be take correct power configuration (Fig. 5-1).

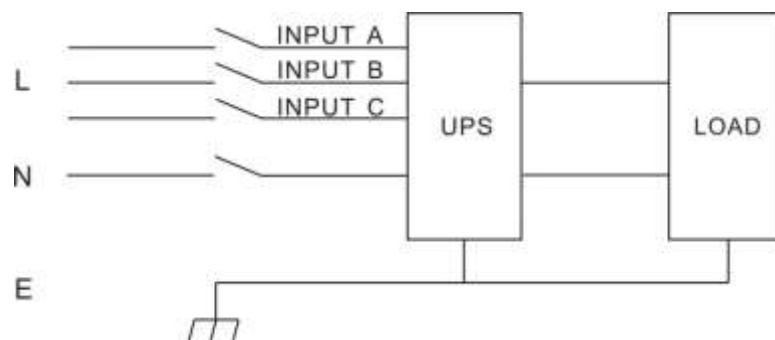

Fig. 5-1 Correct power configuration

5.3 Electrical installation

5.3.1 External battery connection

- 1) Make sure battery quantity complies with the specs (16 to 20 pieces of 12 V batteries in series). Measure voltage of battery bank after finishing connection.



Don't mix batteries with different capacity & brands and don't mix brand new and old batteries, either.

- 2) The breaker on battery cabinet should be off.
- 3) Take out the connection box and remove the cover of terminals, use multi-meter to make sure there is no DC voltage at the battery terminals of UPS.
- 4) Connect battery pole with positive pole, common pole and negative pole to battery connector (BAT+, BATN, BAT-), **don't reverse battery connection** (Fig. 5-2).



It is recommended to connect or replace battery after switching off the system; don't reverse battery polarity when doing battery hot-swapping

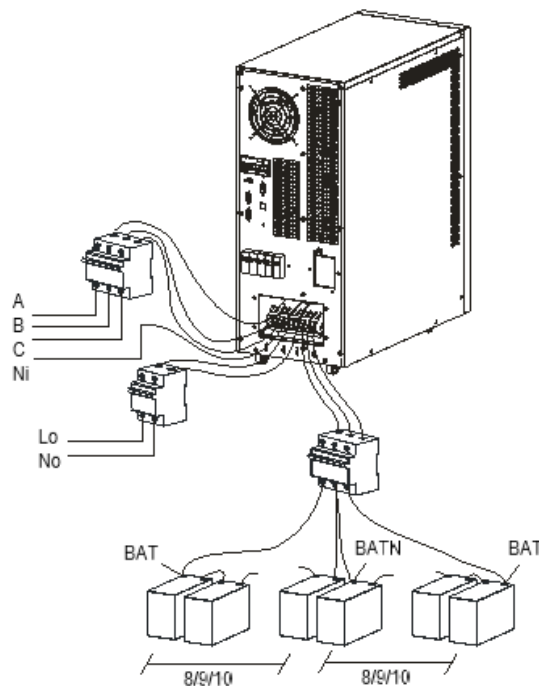

Fig. 5-2 10k/15k/20k External battery connection

5.3.2 UPS input and output connection

Minimum 8AWG or 10 mm² copper wires for input/output & battery cables are required for the ups.

1. Switch off all breakers before connecting cables.
2. Remove the cover of the terminals, see Fig. 5-3, and connect the cables correspondingly

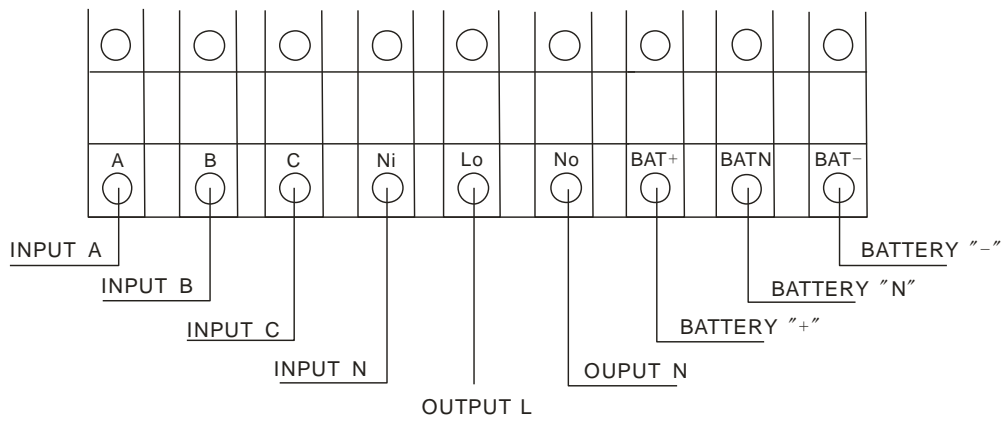

Fig. 5-3 10k/15k/20k I/O terminals connection

SINGLE PHASE WORKING MODE

Normally this UPS is wired as 3-phase mains system 3P+N, but also is designed to be powered by single phase mains P+N, so can be adapted to actual and future installations.

Simply A,B,C 3-phase input terminals must wired be together to convert to single phase mode (P+N)

It is not necessary to change setting inside UPS LCD display.



*Terminators are required so as to ensure the connections are firm.
Don't reverse the input L and N
Don't connect the UPS input to a wall outlet or the outlet will get burnt.*



Please connect the output Earth well before go for other operation

5.4 UPS in parallel

The basic installation procedure of a parallel system comprising of two or more UPS modules is similar than a single module system.

A group of paralleled modules behave as one large UPS system but with the advantage of presenting higher reliability.

A single or multiple battery group can be installed by follow method:

- Individual battery group each UPS
- Common battery group in parallel to whole system

This setting will be stored during manufacturing or can be changed by authorized Service Support.

The following sections introduce the installation procedures specified to the parallel system.

In order to assure that all modules are equally utilized and comply with relevant wiring rules, please follow the requirements below:

- 1) All UPS must be of the same rating and be connected to the same bypass source.
- 2) The Bypass and the Main input sources must be follow the same phase sequence.
- 3) The Bypass and the Main input sources must be referenced to the same middle point potential. (neutral)
- 4) The outputs of all the UPS modules must be connected to a common output bus. (L+N+PE)
- 5) In case of common battery system, BAT + / BAT N / BAT – must be wired correctly between all UPS.
- 6) The length and specification of power cables including the bypass input cables and the UPS output cables should be the same. This facilitates load sharing when operating in bypass mode.

5.4.1 Parallel cabinet installation

Connect all the UPSes needed to be put into parallel system as below picture (Fig. 5-4).

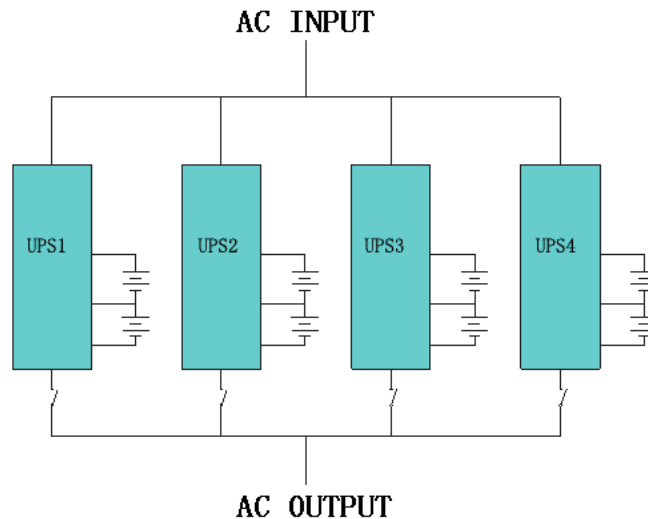

Fig. 5-4 Cabinet installation

- Place all UPS modules together.
- Let minimum rear separation to allow correct ventilation, as specified in general installation procedure.
- Be sure all input and output breakers are in OFF position until initial startup..
- Be sure battery cabinet breaker is OFF until initial startup.



WARNING

Due to this UPS system is based on 3phase input and 1phase output, in case of failure and bypass transfer, total load energy will go through phase 1 (A), so the wiring and protections must be sized properly.

5.4.2 Parallel cable installation

All UPS modules must be interconnected by provided shielded wires in a ring configuration as shown below (Fig. 5-5). The parallel control board is built on each UPS module. The ring configuration ensures high reliability of the control.

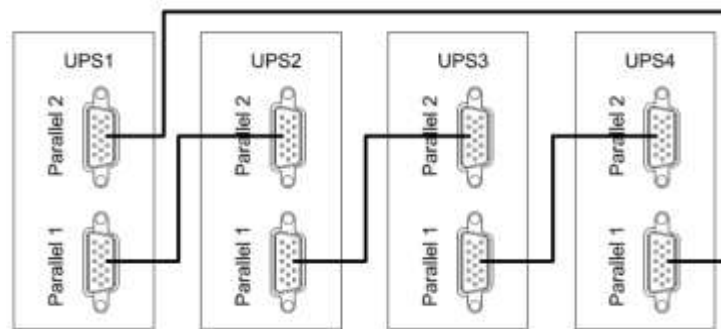

Fig. 5-5 Parallel cable installation

5.4.3 Initial startup procedure for parallel system



WARNING

*Check again that all input and output wires follow the same phase sequence on all parallel UPS.
A.B.C.N.PE / Lo.No.PE*

Follow next steps to first startup procedure:

- 1) Be sure all breakers are in OFF position
- 2) Close AC output breaker
- 3) Close battery cabinet breakers to energize UPS control board
- 4) Finally, close AC input breaker and wait until end of initializing process (1min)

If any alarm is shown, take note and contact ZIGOR Service Support.

6 COMMUNICATIONS

6.1.1 USB communication port definition

RS-232 or USB cable provided in accessories can be used to connect the UPS with PC

Available functions of the USB

- Monitor UPS power status
- Monitor UPS alarm info
- Monitor UPS running parameters
- Timing off/on setting

6.1.1.1 USB and RS232 communication port definition

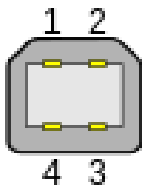

Fig. 6-1 USB male port

UPS USB PORT	DEFINITION
Pin 1 – Vcc	5 Vdc
Pin 2 – D-	USB Data-
Pin 3 – D+	USB Data+
Pin 4 – GND	Ground

Fig. 6-2 USB port pinout

RS-232 communication data format: 2400bps / 8bit / 1bit stop / Parity none

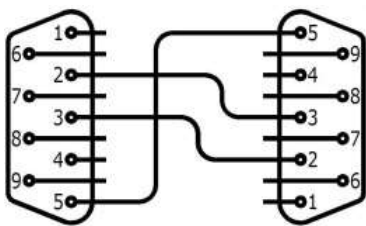

Fig. 6-3 PC to UPS RS232 port

PC RS232 PORT	UPS RS232 PORT	DEFINITION
Pin 2 – RX	Pin 2 – TX	UPS send PC receive
Pin 3 – TX	Pin 3 – RX	PC send UPS receive
Pin 5 - GND	Pin 5 – GND	Ground

Fig. 6-4 Connections between PC RS232 port and UPS RS232 port

USB virtual serial port data format: 9600bps / 8bit / 1bit stop / Parity none

6.2 Intelligent slot

The UPS is equipped with a slot that is designed optionally for either SNMP/Modbus or dry contact cards.

This UPS family has 2 card slots.

- 1 slot for "mini" size cards, mainly for TCP-IP Ethernet communications.
- 1 slot for "standard" size cards, normally for dry-contact alarms (relays).

These slots are Plug&Play, so once the card is inserted, communication will be established without the need for any adjustment on the UPS screen.



Fig. 6-5 SNMP/Modbus card view



Fig. 6-6 SNMPView software image

6.2.1 TCP-IP communications card (optional)

The SNMP/Modbus communications card has an RJ45 female connector to allow advanced UPS management remotely via an Ethernet network.

It also has a mini-USB connection to optionally connect a concentrator (HUB) of environmental sensors with sound alarm. (Temperature, Humidity, Flood,...)

IMPORTANT: INTERNET SECURITY

On newer models these cards includes several advanced security protocols such as HTTPS, SSL, TLS, SNMP v3.

If you are going to expose this card to the internet, you must ensure that you have other protection/security systems that prevent vulnerabilities from being traced, and in any case disable the functionalities that you do not wish to use.

ZIGOR cannot be held responsible for damage caused by cyber-attacks if exposed directly to the internet.

The most common UPS monitoring protocols are included; SNMP and Modbus TCP/IP.

This card, autonomously and without the need for additional software, allows notifications to be sent via e-mail of different events that occur in the UPS. For example, when there is a loss of main AC power supply, an overload due to a short circuit at the output, a defect in the device itself, and others. Even send daily reports of important events.

The most advanced model of this card also allows notifications via TELEGRAM, SKYPE, LINE.

It includes BACnet protocol support, GigaLAN connectivity (1000Mbit), more notifications and selectable recipients and up to 13 languages.

All functionalities can be managed via an integrated web server that can be accessed from any web browser (Safari, Edge, Chrome, Firefox, Edge and others).

A proprietary software package (NetAgent) compatible with various Operating Systems (Windows, MAC, Linux, VMware) is also available to monitor / manage one or multiple UPS simultaneously.

(1) NetAgent updates are limited and there may be incompatibilities on newer OS.

IMPORTANT: ELECTRONIC SECURITY

This card only allows monitoring and modification of certain parameters that do not affect the electronic operation of the UPS.

It is not possible to modify the most important electronic operating settings defined by the display. (voltage, frequency, type and capacity of battery)

To avoid damaging the UPS, these settings must only be made manually and in person by authorised and experienced personnel.

6.2.2 Dry-contact relay card (optional)

Dry contact card has a terminal connector and could be used to monitor UPS status in real time through relay contacts.

Consists of 6 non-programmable contacts and selectable by jumpers: Norm.Open (NO) and Norm.Closed (NC)

The programmed functions are as follows:

PIN	UPS ENERGIZED (NO ALARMS)	Relay	Function	EXAMPLE (MAINS FAIL)
8-1		(K1) J1 / J2	AC mains lost (UPS in battery mode)	
8-2		(K2)	Low battery	
8-3				
8-4		(K3) J3 / J4	Bypass active (unprotected load)	
8-5		(K4) J5 / J6	Internal UPS critical fail	
8-6		(K5) J7 / J8	Inverter mode. ONLINE active	
8-7		(K6) J9 / J10	Rectif, Invert, Temp, Shortcirc alarm	
8	COM		Common terminal	
9	+Vcc		Remote OFF input	Range +5...+12v
10	GND			

Table 6-1 Dry-contact terminals function



J1/J3/J5/J7/J9 default setting NC



Fig. 6-7 Dry-contact card image

For more information or support, please consult its respective manual or contact our Customer Service Support (sac@zigor.com)

6.3 UPS remote access

If you have purchased a communications card:

- Connect the Ethernet cable to establish communication within your LAN.
- Locate and run the NETILITY software (Fig. 6-8)

- It will search your LAN for any compatible communications cards.
- If there are multiple cards detected, you will see a list of all of them.
- By default, DHCP service is enabled for automatic IP assignment.
- Once detected, you will be able to view the IP, MAC address, serial number and firmware version.
- Select the "Launch Web" icon and you will access the card management webserver.

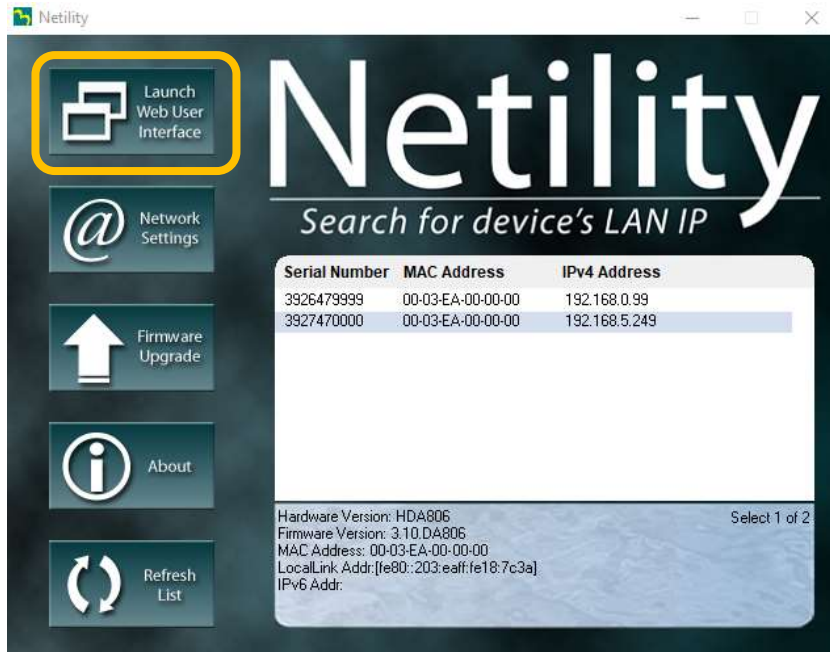

Fig. 6-8 Netility software main screen

6.3.1 IP manual assignment

Using the "Network settings" icon, you can manually assign the IP address to your card, modify the HTTP/HTTPS/Telnet/SSH management ports and assign a main access password to the webserver.

PASSWORD RESET

To reset and disable the password you must remove the card and on bottom PCB will be a model label, then you will see the reset password (the password is unique and non-transferable for each card).

Access the IP of the card `http://xxx.xxx.xxx.xxx/password.cgi` and on the screen that will appear, as user ID: admin and as password: (see label password).

If you lose or do not have this label it will not be possible to reset the card and you will have to buy a new one.

6.3.2 NetAgent webserver main screen

When accessing the webserver through the Netility application or directly if you already know the IP address, you will find a main screen similar to the one shown in (Fig. 6-9)..



Fig. 6-9 NetAgent main webserver screen

- In the "Configuration" menu you can find the main settings of the card (Fig. 6-10).



Fig. 6-10 Configuration menu

Note: The available options may differ depending on the card model purchased or may change without prior notice.

For more information or support, please consult its respective manual or contact our Customer Service Support (sac@zigor.com)

7 TROUBLESHOOTING

7.1 Malfunctions of ZGR VERSATILE 10 - 20 KVA

ZIGOR recommends that, in case of any anomaly, strange noise or supposed malfunction, the equipment should be shut down and ZIGOR customer service should be contacted.

The following table summarizes different anomalous conditions and their possible solution (Table 7-1).

No.	PROBLEM DESCRIPTION	PROBABLE CAUSES	SOLUTION
1	No display on the LCD, no self- diagnostics	A Input power absent B Low input	Use Multi-meter to measure the input to see if it is normal or not.
2	AC normal but AC indicator off, the UPS is in battery mode	A Input circuit breaker off. B Input power connection problem	A Switch on the input breaker B Check the connection and re-do
3	No alarm but no output	Output connection problem	Check the connection and re-do
4	The UPS doesn't start after pressing On button	A pressing ON button time is insufficient B Overload	A Press and hold On button for 1s B Disconnect all loads and restart
5	AC indicator blinking	Input AC is beyond normal range	Pay attention to the backup time if the UPS is in battery mode
6	Abnormal backup time	A Battery not fully charged B Battery Bad	A Charge battery for 8 hours when AC is normal, then test the backup time again B Contact ZIGOR to replace battery
7	Abnormal sound or smell	Fault inside UPS	shut down the UPS immediately and contact ZIGOR
8	Wiring error or phase sequence error	UPS detect wrong phase sequence	Verify correct input phase sequence

Table 7-1 Trouble shooting

Given the complexity of the equipment, when a serious error occurs and causes the equipment to stop, ZIGOR customer service should be contacted to assist you step-by-step to your resolution by providing the information requested.

For more information, contact: www.zigor.com
sac@zigor.com

8 MAINTENANCE

You can ask for an offer to ZIGOR in order to perform a basic maintenance of this equipment, so that it can prolong the life of the system.

In order to guarantee the correct operation of the ZGR VERSATILE 10 - 20 KVA, it is necessary to carry out a number of maintenance tasks. These tasks enable resolving defects before breakdowns occur and to ensure correct operation of active and passive safety devices.

The frequency of maintenance tasks is dependent upon the location and the atmospheric conditions. The air quality (temperature, dust in suspension, etc.) has a great influence on the amount of maintenance work to be done in order to maintain the functionalities of the equipment within an acceptable level of uncertainty. That is, for example, if the air contains a great amount of dust in suspension, the maintenance work must be carried out more frequently than the standard frequency indicated. The recommended maintenance tasks in accordance with frequency are as follows:

- Monthly:
 - Visual control of correct operation:
 - LEDs indicating correct operation.
 - Values within margins.
 - No active event.
 - Control of the event history, in search of sporadic or repetitive failures.
 - Check nothing blocks the ventilation of the front, rear and side panel and the case bottom.
- 6 monthly:
 - Check on the correct ventilation of the location.
 - Cleaning of the equipment's air inlet filters.
 - Removal of foreign bodies both in the air inlet and outlet.
 - Visual verification of the status of connecting wires, rusting, damage to insulation, etc.
- Annually:
 - Cleaning and blowing of electronics.
 - Checking the tightening and condition of the cables, power and signal.
 - Visual checking.
 - Retightening of the connections.
 - Check for colour changes or deformations due to hot spots.
 - Review of hardware (tightening) and wiring (possible rodent involvement or similar).
 - Cleaning control and water filtration of the room where the system is located.
 - Connection of the external AC protections of the equipment (switches, thermal magnets, etc.) and complete controlled start of the equipment.

For some of these maintenance tasks, shutdowns and disconnections must be made.



WARNING

Incorrect maintenance can render the warranty null and void.

- Fan: Continual working time of fan is 20000 to 40000 hours. It will be shorter as temperature raises. Please check the fan periodically, make sure there is wind blowing out from it.
- UPS status checking:
 - Check to see if there is any fault occurred, fault indicator is on or any alarm there.
 - Please find the cause if the UPS is working in bypass mode.

- o If the UPS is working in battery mode, make sure it is normal; on the contrary, please find out the root cause, such as Utility Failure or self-check of battery.

The rest of the installation must also be maintained adequately. The maintenance tasks to be carried out shall depend on the different elements that make up the installation, emergency generator and cabling. The battery requires special attention.

8.1 Battery maintenance



Efficient maintenance lengthens the service life of batteries and ensures that the unit operates correctly.

Placing the batteries correctly so that all their elements can be easily reached facilitates maintenance. Maintenance consists of checking the following aspects:

- Cleanliness: The elements, their connections and supports must be kept clean and dry. It is recommended to protect the terminals and metal connections with diluted vaseline. Do not use cleaning products containing solvents and/or harmful substances for cleaning elements with plastic containers.
- Connections and terminals: Check the tightness of nuts on the poles of elements as well as the tightness of the electrical connection with at regular intervals of approximately 12 months.
- Checking voltages: Check the voltages of elements in order to detect any possible anomalies in these.

There are sealed lead acid maintenance free batteries inside this series standard models. Battery life depends on environment temperature and discharge/charge cycles, it will be shortened if temperature raised or deep discharged. Periodical maintenance is required so as to keep battery in good condition.

- 1) The most proper working temperature is 15 to 25 °C.
- 2) Avoid small discharging current. **Don't let UPS work in battery mode continuously for 24 hours.**
- 3) Charge battery for at least 12 hours every 3 months if it is free of operation. If the environment temperature is high, charge it once every 2 months.
- 4) For extended backup models, check and clean the battery connectors periodically.

If backup time has become much less than before, or there is battery fault displayed on the LCD, please contact distributors to confirm whether the batteries are needed to be replaced or not.



WARNING

Before replacing the batteries, first turn off the UPS and disconnect it from the mains. Take off all metallic ornaments such as rings, watches, etc.

To change the batteries, use a screwdriver with an insulating handle. Do not place tools or metal parts on the batteries.

There should never be a reversal or short circuit between the positive and the negative of the battery.

Do not smoke, light a fire or generate sparks near batteries during recharging as there is a risk of fire and/or explosion.

For cleaning, do not use synthetic material clothes or sponges. Keep batteries clean and dry at all times. Protect them against dirt, dust, metal shavings, etc.

9 TECHNICAL SPECIFICATIONS

Model	ZGR VERSATILE 10	ZGR VERSATILE 15	ZGR VERSATILE 20
Capacity	10 kVA / 10 KW	15 kVA / 15 KW	20 kVA / 20 KW
INPUT ELECTRICAL CHARACTERISTICS (AC)			
Phases	3-phases, 5 wires or single-phase (terminals configurable)		
Nominal Input voltage	380 / 400 / 415 Vac (3Ph+N+PE) 220 / 230 / 240 Vac (L+N+PE)		
Input voltage Range	208 ~ 478 V		
Nominal Frequency	50 Hz/60 Hz		
Frequency range	45 ~ 55 Hz (50 Hz); 55 ~ 65 Hz (60 Hz)		
Power Factor	≥ 0,99		
Bypass voltage range	Max.: 220 V, +25 % (+10 %, +15 %, +20 %, optional) 230 V, +20 % (+10 %, +15 %, optional) 240 V, +15 % (+10 %, optional)		
	Min.: - 45 % (-20 %, -30 %, optional)		
Bypass frequency range	± 1 %, ± 2 %, ± 4 %, ± 5 %, ± 10 %		
Generator Input	Support		
BATTERY (DC)			
Battery number	16/18/20 pieces		
Battery type	VRLA		
Charge mode	Boost charge or float charge auto switch		
Charge time	Boost charge up to 20 hour (max)		
Charge current (max.)	14 A	16 A	18 A
OUTPUT ELECTRICAL CHARACTERISTICS (AC)			
Phases	Single phase, L+N+PE		
Rango tensión de salida	220/230/240 V ±1 %		
Voltage regulation	±1,0 %		
Power factor	1,0		
Frequency	50 / 60 ± 0,1 Hz [Utility Mode: tracking A phase frequency, > ± 10 % (± 1 %, ± 2 %, ± 4 %, ± 5 %)]		
	50 Hz/ 60 ± 0,1 Hz [battery mode]		
Voltage distortion(THD)	less than 2 % at 100 % linear load		
	less than 5 % at 100 % non-linear load		
Load capacity (Mains, drop a level in battery mode)	≤110 %, lasts 1 hour		
	≤125 %, lasts 10 minutes		
	≤150 %, lasts 1 minute		
	> 150 %, switch to bypass		
Load capacity	> 95 %, can not inverter-fed		
	Load for a long time when rated output current under 125%		
	Bypass load capacity is controlled by bypass circuit breaker, tripping when circuit breaker operating current.		
Crest factor	3:1		
Efficiency at AC	Up to 94,5%		
Output voltage DC component	≤100 mV		
Transfer time	0 ms between normal and battery mode		
	0 ms between inverter and bypass (sync mode) , <15ms (async mode)		
COMMUNICATIONS			
Monitorization	LCD+LED		
Communications	USB or RS232 , SNMP (optional) , dry contacts (optional)		

OTHERS			
Protection degree	IP 20		
Noise level	<55 dB (1 m)		
Operation temperature	0 °C – 40 °C		
Relative humidity	0 - 95 % (without condensation)		
Dimensions (W x D x H)	250 x 540 x 635 mm		
Approx. Weight (kg)	43 kg	47 kg	48 kg
STANDARDS			
Marks	CE		
Directives	EN 60950-1, EN 62040-1:2008/A1:2013, IEC 62040-2:2016, IEC 62040-3:2011, ROHS		

- The technical specifications may be modified without prior notice.
- For any other technical need or modification of existing ones, consult ZIGOR

10 STANDARDS

ZGR VERSATILE 10 - 20 KVA model described in this manual comply with the following European regulations:

- I. Directive 2014/35/EU Low Voltage Safety (LVD) for Uninterruptible Power Supply (UPS)
Standard: EN 62040-1: 2008/A1:2013
- II. Directive 2014/30/EU Electromagnetic Compatibility (EMC)
Standard: IEC/EN 62040-2
- III. Comply:
SAI/UPS Classification: EN 62040-3: 2011



11 WARRANTY

Unless otherwise agreed, ZIGOR guarantees that ZGR VERSATILE 10 - 20 KVA units leave the factory in perfect working order and free of any defects for a period of 12 months to be counted as of the date of sale of the apparatus, shown in the delivery note and/or invoice.

ZIGOR will guarantee to the Buyer, the proper functioning against manufacturing and/or workmanship defects. This Warranty includes, whenever the circumstances of good use on the equipment, replace, repair (workmanship included) or refund the purchase price as paid by the customer within the above specified period according to the type of defect and are only and exclusive remedies guaranteed under this Limited Warranty.

The replacement of spare parts, if required, will be made with other new or repaired parts and the replaced ones will become property of ZIGOR.

Unless otherwise agreed, it's not included any assistance and / or displacement. If demanded by the buyer, he'll be held responsible for it.

The customer will be free of charge provided the cause of equipment failure due to defective material thereof, without being affected by the exclusion of warranty causes described in the next section. In any other circumstances be charged the amount of economic displacement.

The following situations will cancel the guarantee of the product:

- Faults due to improper handling of the product, according to the operating instructions, misuse, default grid or by storm.
- Improper use of the equipment according to the Operating Manual and without respecting the original characteristics of the equipment.
- Installation in a place/ environment that does not meet the requirements indicated in the Operating annual referring to the Installation Conditions.
- When the customer not clearly proves the systematic realization of regular maintenance operations described in the Operating Manual.
- Equipment deterioration due to external agents (water, dirt, animals, etc.)
- Damages caused by accident, theft, fire, inadmissible atmospheric conditions, external agents (animals, insects, etc.) or natural disasters.
- In case of any intervention and/or repair by an unauthorised Technical Service.
- The use of equipment or accessories, not sell and/or installed by ZIGOR or their Authorised Technical Service.
- Environmental Operating Conditions out of range.

When the unit is equipped with lead-acid batteries, it must be considered the following precautions:

Those elements are fully charged before shipment. They can be stored for up 2 years provided that they are charged at minimum intervals of 6 months during their storage.

The installation of elements inside the unit by personnel other than those authorised by ZIGOR, shall render the warranty null and void. ZIGOR will not accept responsibility for the repair of equipment if any of the seals installed for internal checks is broken.

The validity of this guarantee is limited to the proper use of the equipment according to the Operating Manual and while respected the original characteristics of the equipment.

The Spanish Standardisation and Certification Association (AENOR) certifies that the "Quality Assurance " and "Environmental Management Systems" adopted by ZIGOR CORPORACIÓN, S.A. for the design, development, production and after sales service for electronic equipment for the conversion of direct and alternating current as well as electronic projections, communications systems, telemanagement applications and electrical and electronic turnkey projects, is an agreement with the requirements of the Spanish Standards UNE-EN ISO 9001 and UNE-EN ISO 14001 respectively.





Zigor Corporación
Portal de Gamarra 28- 01013
Vitoria-Gasteiz Álava/Spain
+34 945 21 46 00
www.zigor.com

*Consulte nuestra web para contactar con la red de delegaciones comerciales
Refer to our website in order to contact the commercial branches network*