

Operation manual



ZGR INFLUENCE HP 50 - 200 KVA

Online three-phase UPS

INDEX

1	PRECAUTIONS	5
1.1	General precautions	5
1.2	Storage precautions	6
1.3	Environmental precautions	7
1.4	Precautions on the transportation of the unit	7
1.5	Precautions on receiving the unit	9
1.6	Symbol Description	9
2	GENERAL DESCRIPTION	10
2.1	Introduction	10
2.2	Main characteristics	10
2.3	Construction of ZGR INFLUENCE HP 50 - 200 KVA	11
3	OPERATION OF ZGR INFLUENCE HP 50 - 200 KVA	14
3.1	Operation Modes	14
3.1.1	Normal mode	14
3.1.2	Battery mode (Stored Energy Mode)	14
3.1.3	Bypass mode	15
3.1.4	ECO Mode	15
3.1.5	Maintenance mode (Manual Bypass)	15
3.2	Turn ON/OFF UPS	16
3.2.1	Initial power-up procedure	16
3.2.2	Test procedure	17
3.2.3	Maintenance bypass	17
3.2.4	Cold Start procedure	18
3.2.5	Shut down procedure	18
4	CONTROL PANEL AND MONITORIZATION	19
4.1	LCD screen	19
4.1.1	Datas menu	20
4.1.2	Status menu	20
4.1.3	Alarm menu	23
4.1.4	Setting menu	24
4.1.5	Maint menu	34
4.1.6	Common menu	37
4.1.7	About Menu	39
4.2	Events and status list	40
4.2.1	Operational Status and Mode(s)	40
4.2.2	Fault Information	40
4.2.3	Alarm Information	42
5	INSTALLATION	44
5.1	Unpack checking	44
5.2	Mechanical installation	44
5.3	Electrical installation	45
5.3.1	External Protective Devices	45

5.4	Connection of Power Cables	45
5.4.1	Recommended cross-sectional areas for power cables	46
5.4.2	Power cable connector requirements	47
5.4.3	Recommended input front-end and output back-end circuit breakers	48
5.5	Power cable connection	49
5.5.1	Common input connection	49
5.5.2	Dual input connection	50
5.6	Battery connection	52
5.7	UPS parallel Installation	53
5.7.1	Cabinet installation	54
5.7.2	Parallel cable installation	54
5.7.3	Parallel setting	55
5.7.4	LBS installation	57
5.8	Communications	58
5.8.1	USB communication port definition	58
5.8.2	RS485 communication port definition	60
5.8.3	Optional port definition	61
5.8.4	REPO instruction	61
5.9	UPS remote access	62
6	OPTIONS	64
6.1	SNMP card	64
6.2	Relay card	64
7	TROUBLESHOOTING	65
7.1	Malfunctions of ZGR INFLUENCE HP 50 - 200 KVA	65
7.2	Recommended spare parts	66
8	MAINTENANCE	67
8.1	Battery maintenance	68
9	TECHNICAL SPECIFICATIONS	69
10	STANDARDS	71
11	WARRANTY	72

© 2022, ZIGOR

All rights reserved. The total or partial reproduction of this User Manual, or its transmission of any type or by any means, be this mechanical or electronic, by means of photocopies, registration or other information storage or recovery procedure, without the permission of the editor, is totally forbidden.

The contents of this manual are exact at the time it was printed. However, with the intention of complying with our aim of continuous development and improvement, the manufacturer reserves the right to change the specifications of the product, its operation or the contents of the Operating Manual without prior warning.

1 PRECAUTIONS

1.1 General precautions

For your own safety and that of the unit, you must read and understand the instructions contained in this document before starting work.

Keep these instructions in a place accessible to all the personnel who work with the unit so that they can be consulted.

Only expert and duly authorised personnel may operate our units.



Danger warnings. When handling or accessing the interior of the ZGR INFLUENCE HP 50 - 200 KVA, please remember that some parts may be live. Pay special attention to soldering points, printed circuits, connecting terminals, relay contacts, etc. Before opening the equipment, disconnect the voltage of all poles (both alternating and direct) and wait at least 5 minutes for the internal condensers to discharge.

Arbitrary modifications are forbidden. The unit must not be subjected to any modification regarding its construction or safety without **ZIGOR's** express consent. Any modification will free ZIGOR of any responsibility for any damage caused as a result of the modification. In particular, all repair work, soldering of printed circuit boards and replacing of components, modules and printed circuit boards, without the express authorisation of ZIGOR, is forbidden. Should spare parts be used, only ZIGOR original parts shall be utilised.

Use the unit for the purpose for which it was designed. The system supplied must be used only for the purpose for which it was designed. Any other use is strictly forbidden. ZIGOR cannot accept responsibility for any damage that might result from its use for any other purpose. In such cases, the user shall assume exclusive responsibility for any risk. The use for which the unit was designed is defined in the documentation. The system shall be exposed only to admissible environmental conditions. These are defined in the technical details provided for the equipment.

ZIGOR accepts no responsibility for any inadequate, negligent or incorrect installation of the equipment.



WARNING

This supply equipment contains a lethal voltage. Comply with the instructions set out in this manual to avoid any risk of electrical shock.

Please follow the indications set out below to operate under conditions of complete safety:

- The System must be checked once the installation has been completed by a qualified technician and before being put into operation. Should these indications not be adhered to, the warranty shall be considered null and void.
- These units do not contain parts usable for other purposes by the user.
- Do not power up the device before a technician has checked it.
- Given the risk of electric shock or burns, do not try to open the device.
- Work inside the cabinet should be undertaken only by qualified personnel who are familiar with the safety measures to be applied and the specific technical characteristics of the unit.
- The unit does not contain any user repairable or replaceable elements. In the case of any malfunction or problems operating the unit, please contact ZIGOR.
- Do not place the system near power magnets as this might cause a malfunction.
- Do not block or cover the ventilation grills in the housing.
- The ZGR INFLUENCE HP 50 - 200 KVA is designed in accordance with current Spanish legislation. Check these regulations against those corresponding to the country in which the unit is to be installed and against the most restrictive regulations of the electricity supplier.
- All user controls are accessible from the exterior.
- Should you have any problems with the contents of this manual, you must ask ZIGOR for assistance.

- This system has been designed for industrial use and not for domestic-commercial use.
- Even though all the safety systems are in place, before touching any working parts, you must check that they are not live.
- If any liquid is spilt accidentally on the System, disconnect it and call to ZIGOR support.
- During assembly work, start-up or maintenance, wear goggles to avoid any damage to your eyes due to accidental electric arcing.
- Use only insulated tools.
- The unit must be protected against rain and excess humidity and installed in a clean atmosphere, without inflammable liquids, gases or oxidising substances.
- The battery may pose a risk of electric shock or burns due to its high short circuit current.
- If the batteries lose electrolyte or are physically damaged, they must be placed in a container in resistant to corrosive liquids (acids or alkaline according to the type of battery) and prepared in accordance with local regulations.
- If the electrolyte comes into contact with the skin, the affected area must be washed immediately with clean water.
- For the sake of human being safety, please well earth the UPS before starting it.
- Do not throw batteries into a fire as they may explode.
- UPS models with internal batteries can be powered even when the UPS input is not connected to the mains.
- Do not disconnect the input from the UPS and make sure the UPS is completely off before moving it or reconfiguring the connection; otherwise, there is a risk of electric shock.
- Only authorized personnel should repair or install the batteries.

1.2 Storage precautions

The store where the material is kept must protect the material from the elements, risk of flooding or contact with water.

The material shall be protected from any risk of overheating due to exposure to direct sunlight or through windows.

The recommended storage temperature is between 15°C to 25°C. An increase of 10°C can reduce the service life of the battery by 50%. The recommended relative humidity is from 30% to 90%.

For a long storage period, it is recommended to make a battery recharge during 12hours each 3 months to **maintain battery life and reduce “memory effect” for PB batteries.**

To avoid any risk of mechanical shock, do not stack the packages. These must be placed in accordance with the silkscreen printed details on the boxes used for packaging.



WARNING

Any failure to respect these precautions may render the product warranty null and void.

1.3 Environmental precautions



Dispose of the packaging in an ecological way: ZIGOR, based on the exceptions detailed in the First Additional Provision of Law 11/1997 on commercial or industrial packaging, informs that the final holder of the waste of used containers and packaging, as responsible for them, you must deliver them in appropriate conditions for reuse, to an authorized recuperator, recycler or re-valuer.

The subsets of the system are recyclable products and cannot be treated as household / municipal waste at the end of its useful life.

To preserve the environment, manage them in accordance with current environmental regulations and requirements in each country or community. In case of doubt, consult the manufacturer.



Correct product disposal: This electrical-electronic device (AEE) is marked with the symbol of compliance with the European Directive 2012/19 / EU (WEEE) regarding used electrical and electronic equipment (Waste electrical and electronic equipment WEEE, RD 110/2015).

The Directive provides the general framework valid throughout the European Union for the removal and reuse of waste from EEE.

To dispose of this product and ensure its proper management, follow the current local environmental legislation and regulations. In this way it will contribute to conserve the

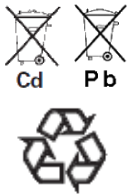

Correct disposal of batteries: Used batteries are reusable consumer products and a recycling process must be carried out.

Used batteries that do not go through the recycling process must be disposed of according to the instructions regarding special waste, in accordance with the regulations and environmental requirements in force in each country or community. This requirement applies in the European Union and in those places where separate collection systems are available.

In case of doubt, consult the manufacturer.

In this way it will contribute to conserve the environment.

1.4 Precautions on the transportation of the unit

Please transport the UPS system only in the original package to protect against shock and impact. The procedure to transport of the UPS to the final location should follow the procedure:

1. Use a pallet truck to transport the UPS to the installation position.
2. Check the UPS packing.
3. Hold the sliding plate steady. Cut and remove the binding tapes (Fig. 1-1).

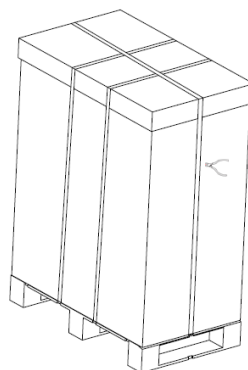

Fig. 1-1 Removing the fastening tapes

4. Remove the plastic bag and take out the fittings box.
5. Check that the UPS is intact.

Visually inspect the UPS appearance for shipping damage. If it is damaged, notify the carrier immediately.

Check the accessories according to the packing list and contact the dealer in case of missing parts.

6. Remove the front panel and rear panel to remove the L-shaped bracket that secures the cabinet and the pallet, and secure the sliding (Fig. 1-2).

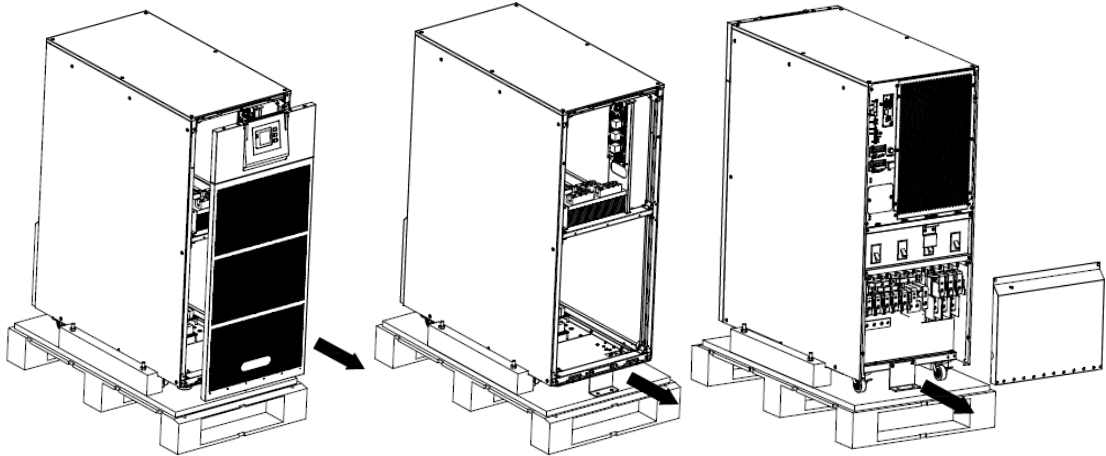

Fig. 1-2 Front and rear panel removal

7. Remove the front panel and rear panel to remove the L-shaped bracket and the plates at the left and right side of the UPS that secures the cabinet and the pallet, and secure the sliding (Fig. 1-3).

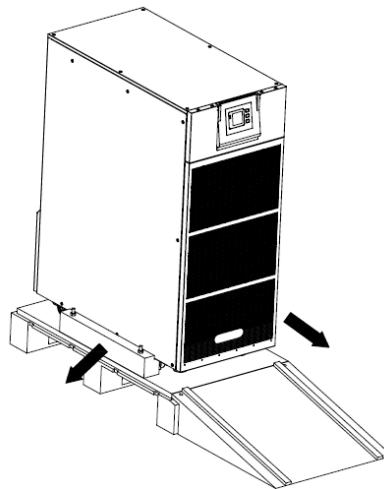

Fig. 1-3 Removing the original packaging

1.5 Precautions on receiving the unit

Visually check that the warehouse location is adequate by checking its characteristics (clean, free of leaks with good ventilation); the floor must be level and have sufficient load resistance for the equipment.

Checking the material

Do not lean the UPS when moving it out from the packaging.

On receiving the material, a visual inspection should be made in order to detect any anomalies that may have occurred during transport.

List and check all the items indicated on the delivery note. Should any component be missing, notify the forwarding agent within the established deadline.

Extract all parts from the packaging and examine the unit for any damage caused during transport.

Report any damage to the forwarding agent and ZIGOR.

Check that the material delivered corresponds to the delivery note. Check the manufacturer's label placed at the rear or on one side of the unit.

Responsibility for the loss or damage of Products shall transfer to the Customer from the moment ZIGOR, places these at his disposal in the place indicated by the Customer.

From then on, the customer will have 24 hours to make any claim under guarantee for any anomaly in the amount or quality of the products received, providing details of the material received in bad condition after reporting this circumstance on the forwarding agent's delivery note on reception.

Should the customer not report any defect within 24 hours, it will be understood that he has accepted delivery of the unit.

1.6 Symbol Description

The safety symbols cited in this manual are shown in Table 1-1, which are used to inform readers of safety issues that should be obeyed when installation, operation and maintenance.



SECURITY SYMBOL	INDICATION
	Attention
	Sensitive to electrostatic discharge
	Risk of electric shock

Table 1-1 Symbols meaning

2 GENERAL DESCRIPTION

2.1 Introduction

ZGR INFLUENCE HP 50 - 200 KVA is an intelligent, three phase in Three-phase out, high frequency online UPS with small footprint.

ZGR INFLUENCE HP 50 - 200 KVA range expands its options with a range from 50 kVA to 180 kVA and improves its technology with a 3-stage inverter, which results in a lower loss of power in conversion and achieves an efficiency up to 95.5%.

In this range of power, ZGR INFLUENCE HP 50 - 200 KVA offers a PF 1.0 for its loads which make it suitable for all types of installations that demand high energy quality and best energy efficiency.

ZGR INFLUENCE HP 50 - 200 KVA can solve most of the power supply problems, such as blackout, over-voltage, under-voltage, voltage sudden drop, high voltage pulse, voltage fluctuation, surge, inrush current, harmonic distortion (THD), noise interference, frequency fluctuation, ...

This UPS can be applied to different applications from computer device, automatic equipment, communication system to industry equipment. They are available in a Dual Input version that allows a three-phase auxiliary bypass grid.

With excellent electrical performance, perfect intelligent monitoring and network functions, smart appearance, complying with **EMC and safety standards**, **The UPS meets the world's advanced level.**

2.2 Main characteristics

- 3 Phase In / 3 Phase Out with separate bypass input (dual input)
- Online double conversion with DSP control
- Dual input (optional)
- Output power factor of 1.0
- Low input and output current distortion
- Efficiency of 95,5 %
- Parallelable up to 6 units
- Active ECO function: Minimize UPS self-consumption and improves efficiency up to 98%
- Allows common battery in parallel mode
- **7" colour touch screen** and LED indicators
- Compatible with generator sets
- Integrated Input/output/bypass MCB protections
- Standard models are designed for external long autonomy battery
- Configurable battery charge voltage and current
- Periodic battery test configurable
- Cold start and Auto Restart function
- Compatible with Ni-Cd / Lilon (on demand)
- Internal batteries (optional)
- Communications: 2 independent bays for smart cards and dry contacts
- Daisy chain RS485 port with built-in Modbus RTU protocol

2.3 Construction of ZGR INFLUENCE HP 50 - 200 KVA

Front views for ZGR INFLUENCE HP series (Fig. 2-1, Fig. 2-2, Fig. 2-3, and rear connections (Fig. 2-4, Fig. 2-5, Fig. 2-6):

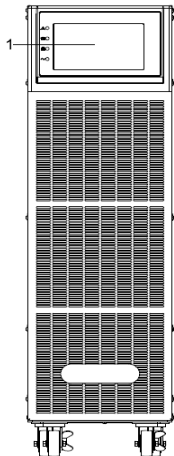

Fig. 2-1 Front view
50-60 kVA ¹

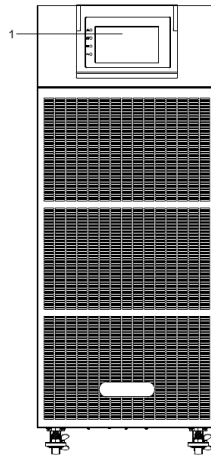

Fig. 2-2 Front view
80-150 kVA ¹

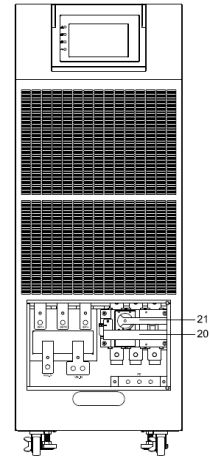

Fig. 2-3 Front view
180-200 kVA ¹

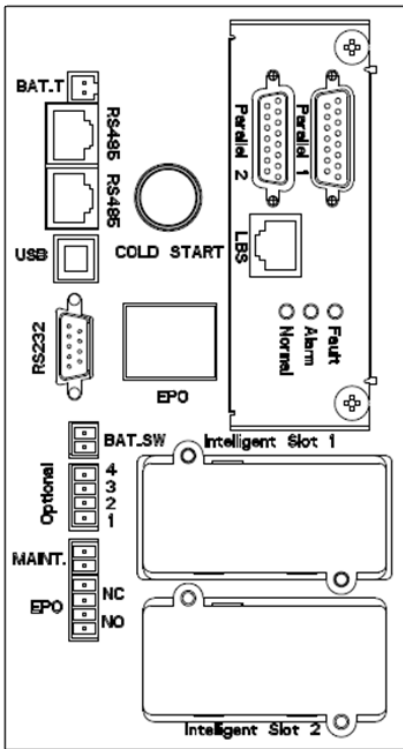

Fig. 2-4 Connections
ZGR INFLUENCE HP 50 – 60 kVA ²

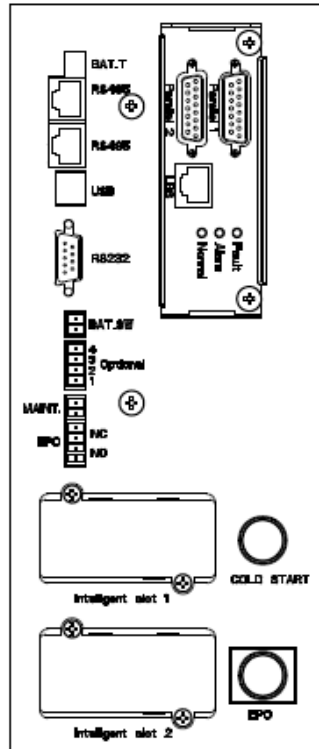

Fig. 2-5 Connections
ZGR INFLUENCE HP 80 – 120 kVA ²

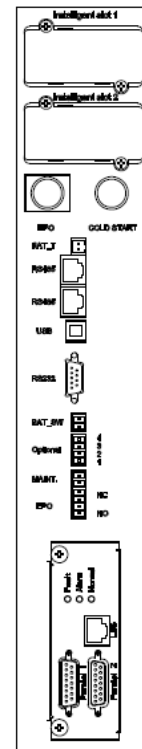

Fig. 2-6 Connections
ZGR INFLUENCE HP 150 – 200 kVA ²

¹ Front view may change without notice.

² Rear view and connection location may change without notice.

Following by general rear views (Fig. 2-7, Fig. 2-8, Fig. 2-9, Fig. 2-10)

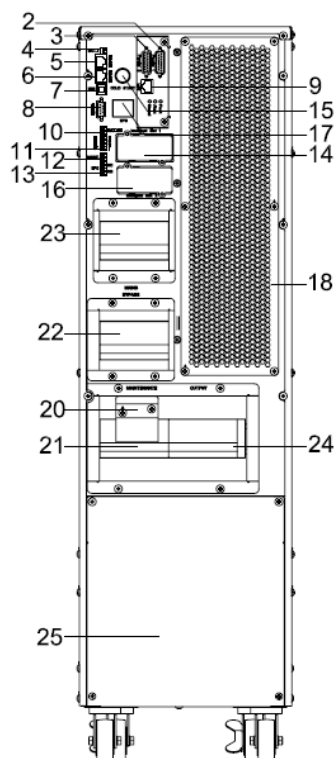

Fig. 2-7 Rear view
ZGR INFLUENCE HP 50-60 kVA³

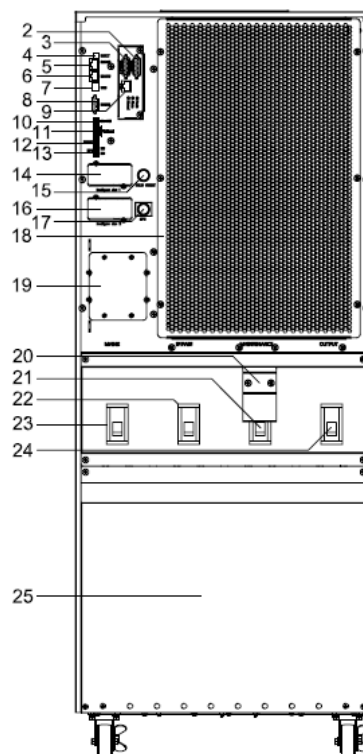

Fig. 2-8 Rear view
ZGR INFLUENCE HP 80-120 kVA³

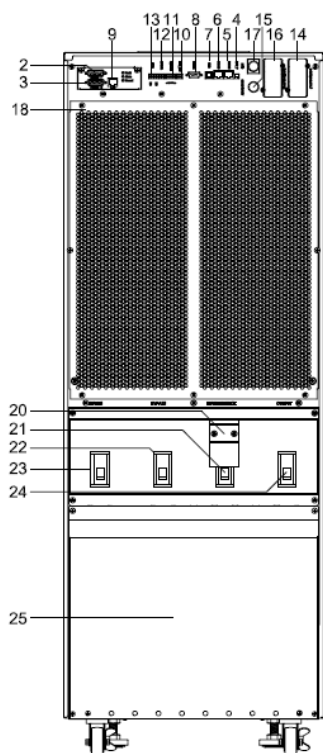

Fig. 2-9 Rear view
ZGR INFLUENCE HP 150 kVA³

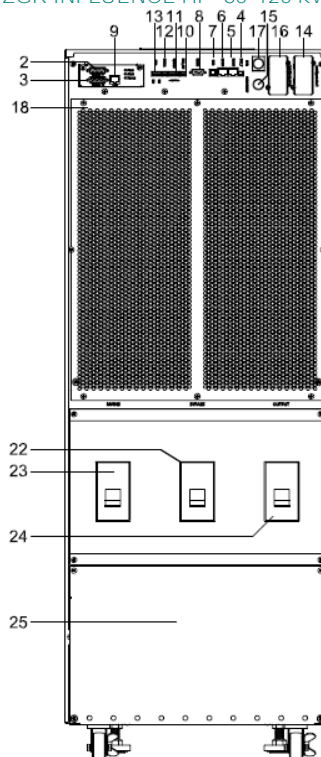

Fig. 2-10 Rear view
ZGR INFLUENCE HP 180-200 kVA³

³ Rear view and connection location may change without notice.

Connectors description:

- (1) LCD panel
- (2) Parallel port 1
- (3) Parallel port 2
- (4) Temperature sensor port (for NTC)
- (5) RS485 port
- (6) RS485 port
- (7) USB comm. port
- (8) RS232 comm. port
- (9) LBS port (master/slave system)
- (10) BAT_SW : external battery switch status input
- (11) Optional port
 - feedback breaker trigger output
 - battery LVD breaker trigger output
- (12) MAINT port
 - external maintenance breaker status input
- (13) REPO port (remote emergency power OFF)
- (14) Intelligent port 1
- (15) Cold-start (w/o Mains)
- (16) Intelligent Slot 2
- (17) Emergency EPO button
- (18) Maintenance and cooling cover
- (20) Maintenance breaker cover
- (21) Maintenance Bypass breaker
- (22) Bypass input breaker
- (23) Mains breaker
- (24) Output breaker
- (25) Terminal block cover

LCD panel:

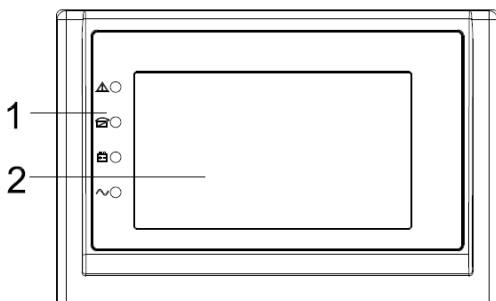

- (1) Informative LED
 - UPS Fault
 - Bypass ON
 - On battery
 - Inverter ON)

- (2) LCD touch screen

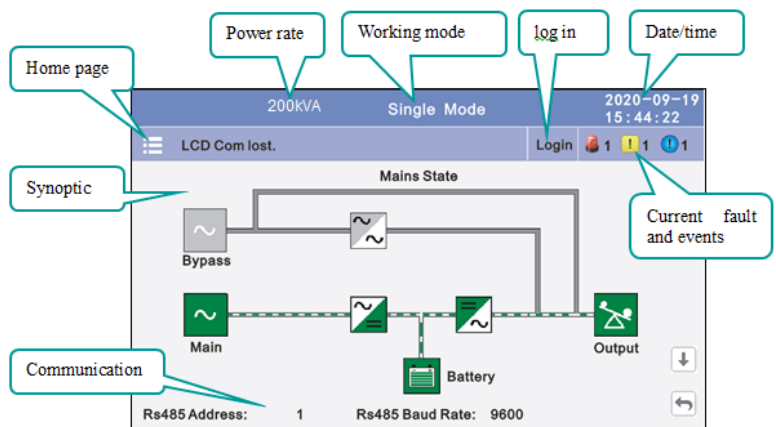

3 OPERATION OF ZGR INFLUENCE HP 50 - 200 KVA

3.1 Operation Modes

This UPS adopts advanced three-stage charging method:

1st stage: high current constant current charging to guarantee to charge back to 90% (CC)

2nd stage: Constant Voltage in order to vitalize battery and make sure batteries are fully charged (CV)

3rd stage: constant maintenance voltage. Floating mode

With this 3-stage charging method, it extends the life of the batteries and guarantees fast charging.

Besides, the UPS is a double-conversion on-line UPS that may operate in the following alternative operation modes.

3.1.1 Normal mode

The rectifier/charger derives power from the AC Mains and supplies DC power to the inverter while floating and boosting charge the battery simultaneously. Then, the inverter converts the DC power to AC and supplies to the load (Fig. 3-1).

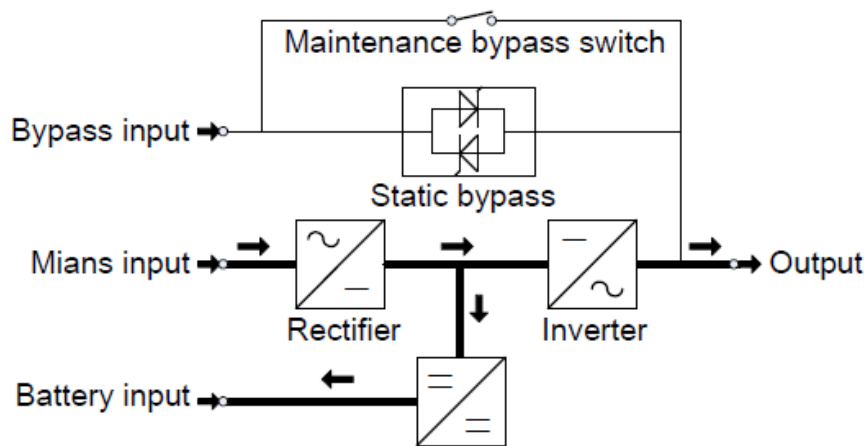

Fig. 3-1 Normal mode

3.1.2 Battery mode (Stored Energy Mode)

If the AC mains input power fails, the inverter, which obtains power from the battery, supplies the critical AC load. There is no power interruption to the critical load. The UPS will automatically return to Normal Mode when AC recovers (Fig. 3-2).

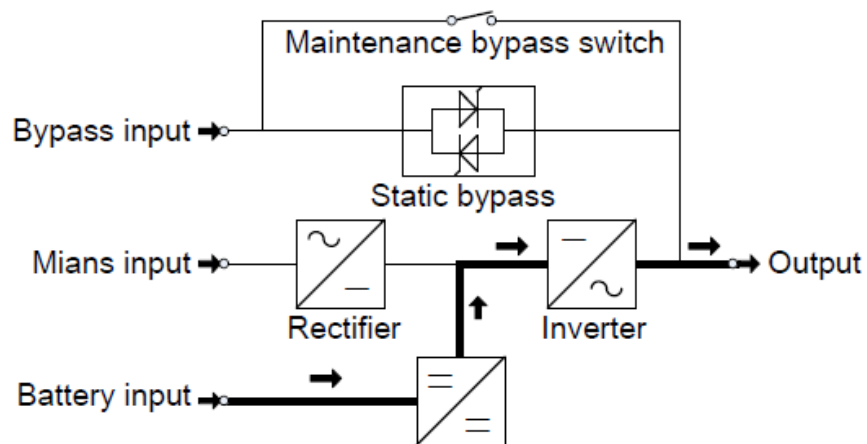

Fig. 3-2 Battery mode

3.1.3 Bypass mode

If the inverter is out of order, or if overload occurs, the static transfer switch will be activated to transfer the load from the inverter supply to bypass supply without interruption to the critical load (Fig. 3-3).

In the event that the inverter output is not synchronized with the bypass AC source, the static switch will perform a transfer of the load from the inverter to the bypass with power interruption to the critical AC load. This is to avoid paralleling of unsynchronized AC sources. This interruption is programmable but typically set to be less than an electrical cycle e.g. less than 15 ms (50 Hz) or less than 13,33 ms (60 Hz).

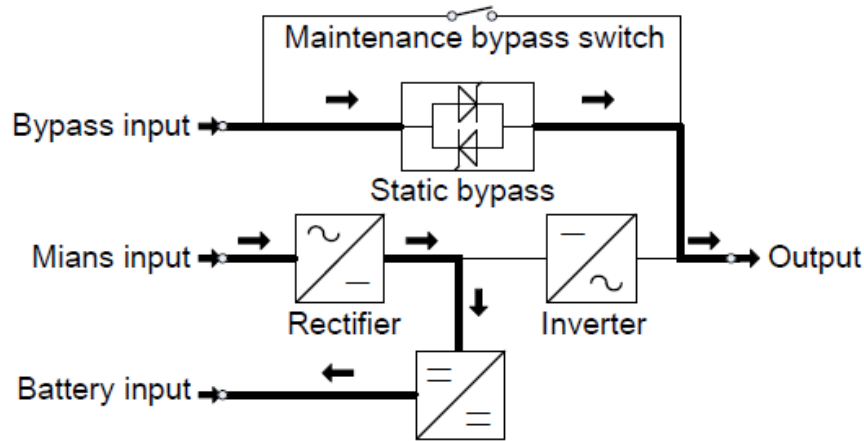

Fig. 3-3 Bypass mode

3.1.4 ECO Mode

When the UPS is at AC Mode and the requirement to the load is not critical, the UPS can be set at ECO mode in order to increase the efficiency of the power supplied (Fig. 3-4). At ECO mode, the UPS works at Line-interactive mode, so the UPS will transfer to bypass supply. When the AC is out of set window, the UPS will transfer from bypass to Inverter and supplies power from the battery, and then the LCD shows all related information on the screen.

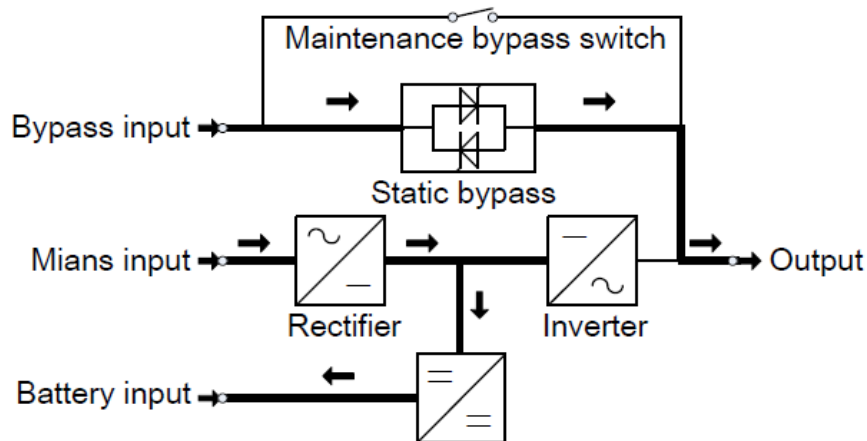

Fig. 3-4 ECO mode

3.1.5 Maintenance mode (Manual Bypass)

A manual bypass switch is available to ensure continuity of supply to the critical load when the UPS is out of order or in repair and this manual bypass switch bears for equivalent rated load (Fig. 3-5).

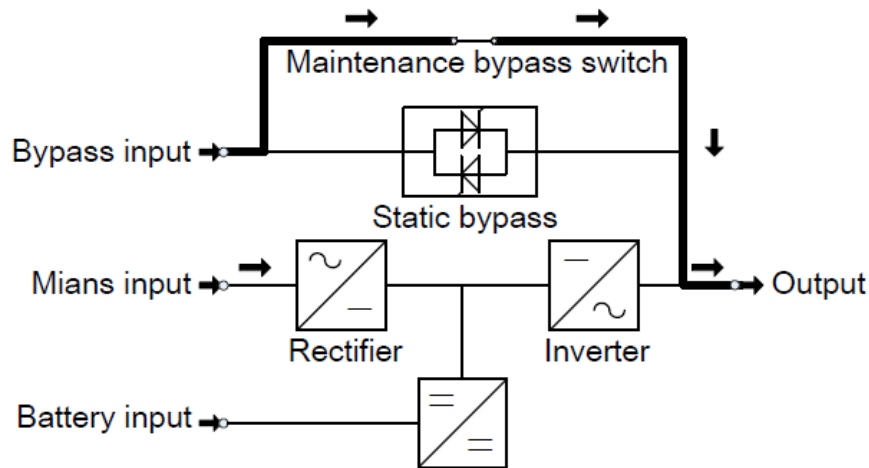

Fig. 3-5 Maintenance mode

3.2 Turn ON/OFF UPS

3.2.1 Initial power-up procedure



WARNING

Make sure grounding is properly done.



WARNING

Check to see if the load is safely connected with the output of the UPS. If the load is not ready to receive power from the UPS, make sure that it is safely isolated from the UPS output terminals.

1. Set the Battery Breaker to "ON" position.
2. Turn ON Mains breaker.
3. Turn ON Bypass breaker.

If the Rectifier input is within voltage range, the rectifier will start up in 30 seconds then the inverter will start up.

During Rectifier start up, the UPS will remain in Static Bypass mode. (bypass LED will light up)

When complete, it continues on Battery Charging mode and Inverter start-up.

If all procedure is OK, UPS will finally transfer from Bypass mode (yellow LED off) to Inverter mode. (ONLINE green LED)

No matter whether the UPS can work normally or any issue is detected, all the status will be shown on the LCD display.

4. Verify all your loads are ready and turn ON output breaker.



WARNING

If the UPS is operating normally, It may take about 60 seconds to perform full self-test completely.

3.2.2 Test procedure

UPS in fully stable ONLINE working mode and fully charged batteries:

1. Switch off the mains power to UPS to simulate utility failure, the rectifier will turn off and the battery should feed energy through the inverter without interruption. At this time, the on battery mode yellow LED should be turned on and battery will be on discharging mode..
2. Switch on the MAINS to simulate utility recovery, the rectifier will restart automatically, after 30 seconds rectifier will supply to Inverter and charger starts recover charging mode.

It is suggested to use Dummy loads for testing.

3.2.3 Maintenance bypass

To supply the load via Mains, you may simply active the internal mechanical bypass switch.

When maintenance bypass cover is removed, UPS will set static bypass automatically.



WARNING

The loads are not protected by the UPS when the internal mechanical bypass system is active. Any mains fluctuation, interference, energy loss,... will be applied directly to loads.

3.2.3.1 Switch to mechanical bypass



WARNING

If the UPS is running normally, for more security, it is recommended to transfer to static bypass initially by LCD display. Locate Inverter related menu and select "Inverter OFF" option. Then continue to steps 1 -6.

1. Open the cover of maintenance switch, the UPS turns to bypass mode automatically.
2. Turn ON Maintenance breaker.
3. Turn OFF Battery breaker if full UPS isolation is needed.
4. Turn OFF Mains breaker.
5. Turn OFF auxiliary mains Bypass breaker.
6. Turn OFF Output breaker.

At this time the bypass source will supply to the load through the MAINTENANCE breaker.

3.2.3.2 Return to normal operation (from mechanical bypass)



WARNING

Never attempt to switch the UPS back to normal operation until you have verified that there are no internal UPS faults.

1. Turn ON Battery
2. Turn ON Output breaker.
3. Turn ON auxiliary mains Bypass breaker.

4. Turn ON Mains breaker and wait until fully start-up process.
5. Switch OFF the maintenance bypass breaker and put maintenance switch cover.

If the inverter works normally, the system will be transferred from bypass mode to normal Online mode.

3.2.4 Cold Start procedure



WARNING

Follow these procedures when the input AC Utility Failure, but battery is normal.

1. Turn on the Battery breaker. The battery will power internal auxiliary power boards.
2. Turn on the Output breaker.
3. Trigger the Cold start button, position 11 of the below drawing (Fig. 3-6).

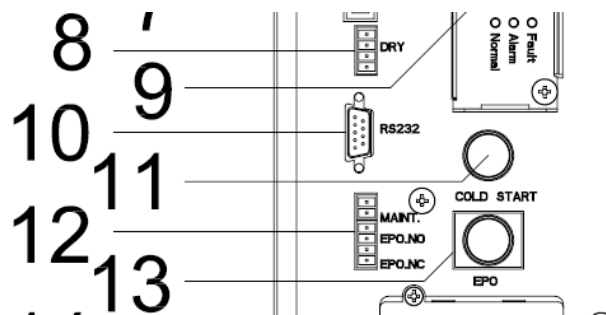

Fig. 3-6 Cold Start

When battery is under normal working ranges, rectifier starts operation, 30s later, it then inverter starts and operates. UPS will be working on battery discharging mode (yellow LED On).

3.2.5 Shut down procedure



WARNING

This procedure should be followed to completely shut down the UPS and the output loads.

After all power switches, isolators and circuit breakers are opened, there will be no output.

1. Turn OFF Battery breaker. (UPS could notify battery fault alarm)
2. Turn OFF Mains breaker. (UPS could notify alarms during internal electronics discharge)
3. Turn OFF Bypass breaker. (Loads will be powered off)
4. Turn OFF Output breaker.
5. Normally the primary input distribution panel is often located far away from the UPS area, so a label should be posted to advise service personnel that the UPS circuit is under maintenance.



WARNING

Wait for about 5 minutes for the internal DC bus bar capacitors to be completely discharged to avoid any electric shock risk.

4 CONTROL PANEL AND MONITORIZATION

4.1 LCD screen

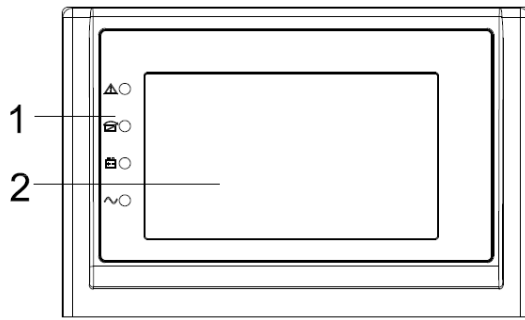

1. status LED
 - * UPS fail
 - * Bypass mode
 - * Battery mode
 - * Inverter ON
2. LCD touch screen

Fig. 4-1 LCD Control panel

WARNING

The display could show different texts and translation depend on selected language, and could show more functions than those described in this manual.

Contact ZIGOR service support for help.

In the LCD screen the following elements and areas are shown (Fig. 4-2):

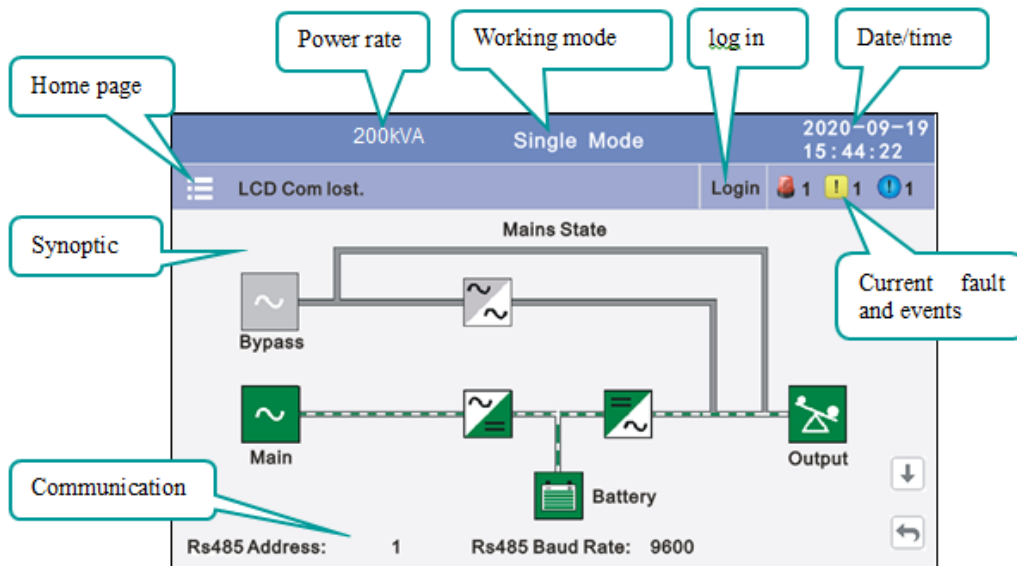

Fig. 4-2 Control panel distribution screenshot



Click the main block to enter the main data display window, click return to return to the previous window, click home page to return to the main page.

4.1.1 Datas menu

This menu displays the flow state of UPS work, and quickly enters real-time data by clicking on the block (Fig. 4-3).

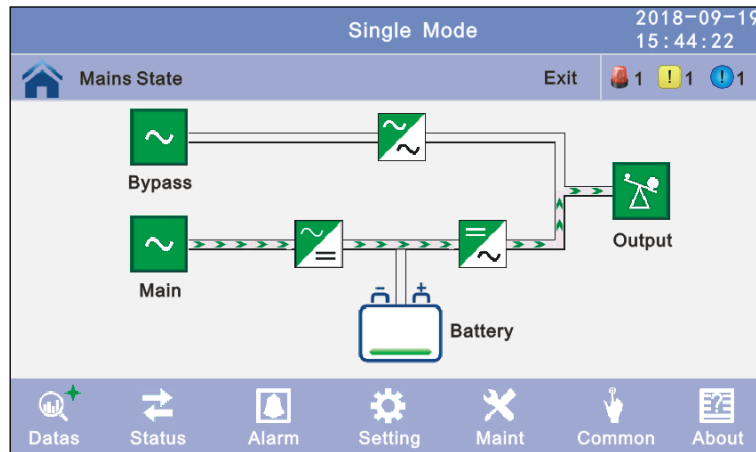

Fig. 4-3 Datas menu

4.1.2 Status menu

In this window it can be viewed the voltage and current of the main, bypass, output, battery (Fig. 4-4). Moreover, it can also be entered through by real-time data block), the status of the switches, dry contacts, through clicking on the block, enter the corresponding data window.

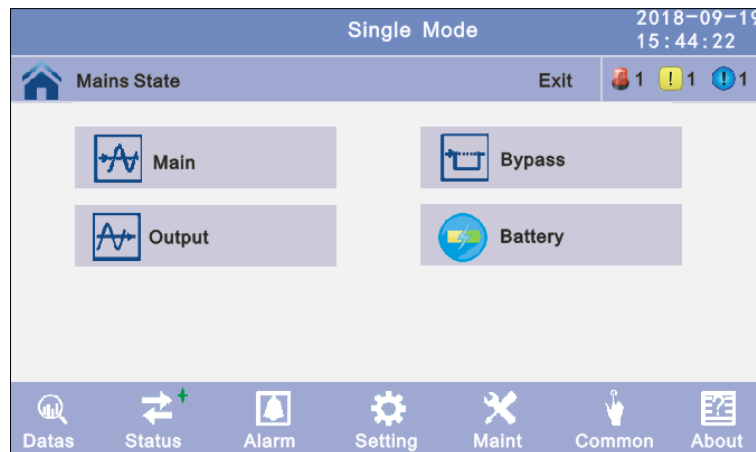

Fig. 4-4 Status menu

4.1.2.1 Main submenu

Clicking on the main block, it can be accessed the main data display window and open the network status display screen (Fig. 4-5).

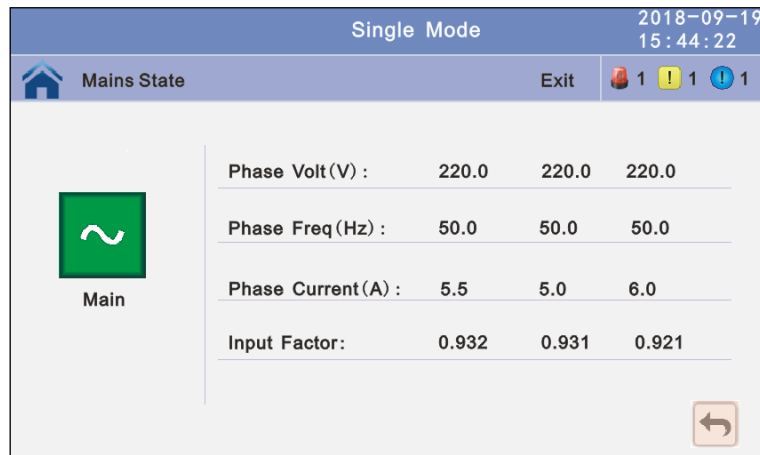

Fig. 4-5 Status/Mains State submenu

4.1.2.2 Bypass submenu

Click the bypass block to enter the bypass data display window (Fig. 4-6).

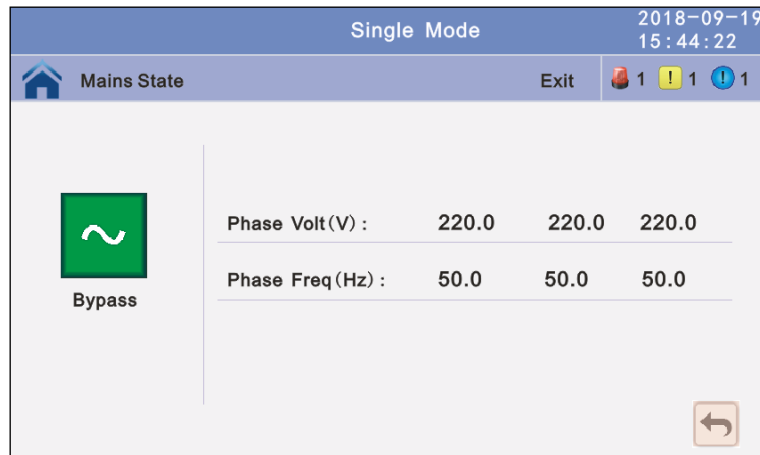

Fig. 4-6 Status/Bypass submenu

4.1.2.3 Output submenu

Click the output block to enter the output data display window (Fig. 4-7 and Fig. 4-8).

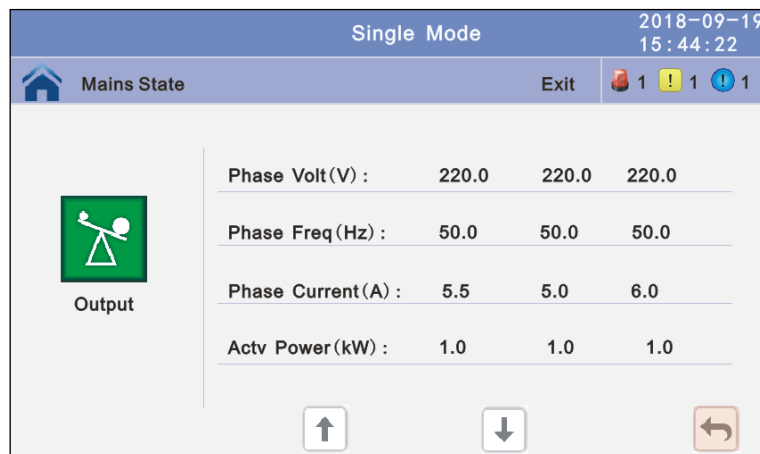

Fig. 4-7 Status/Output (1) submenu



Fig. 4-8 Status/Output (2) submenu

4.1.2.4 Battery submenu

Click the battery block to enter the battery data display window (Fig. 4-9 and Fig. 4-10).

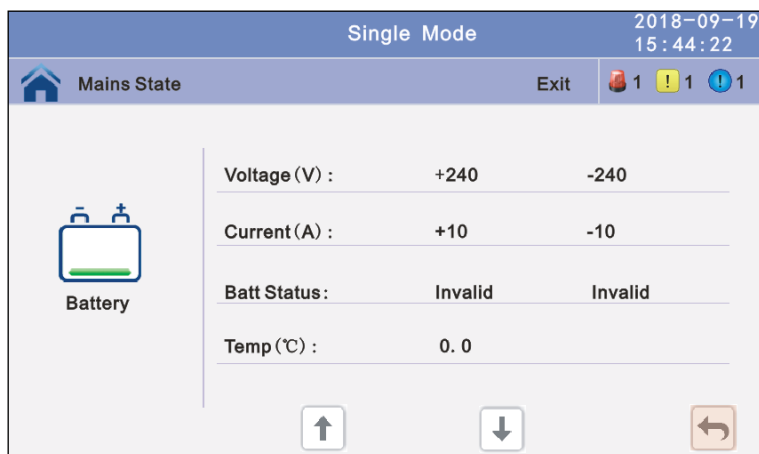

Fig. 4-9 Status/Battery (1) submenu



Fig. 4-10 Status/Battery (2) submenu

4.1.3 Alarm menu

It allows viewing the alarms and history of the UPS, and activating or deactivating the buzzer (Fig. 4-11).

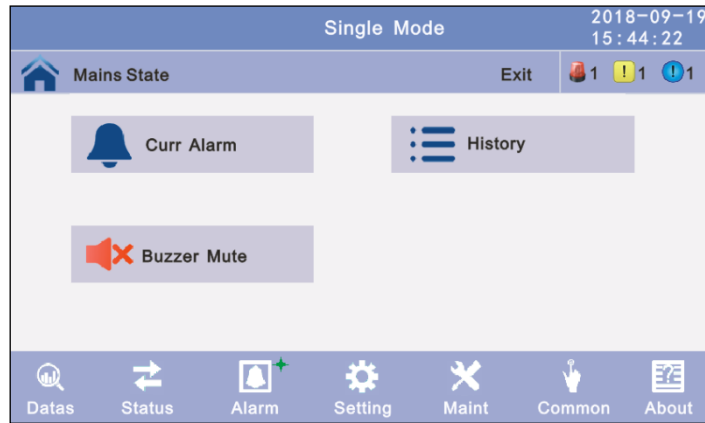

Fig. 4-11 Alarm menu

4.1.3.1 Curr Alarm submenu

Click the curr alarm to enter the current alarm display window (Fig. 4-12).

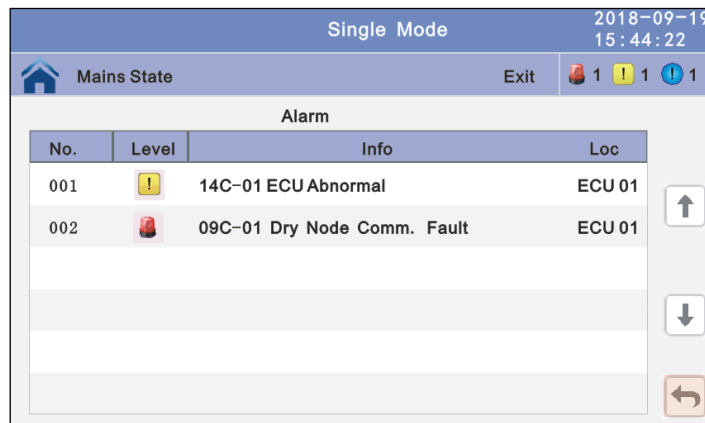

Fig. 4-12 Alarm/Curr Alarm submenu

4.1.3.2 History submenu

Click the history to enter the history recode display window (Fig. 4-13).

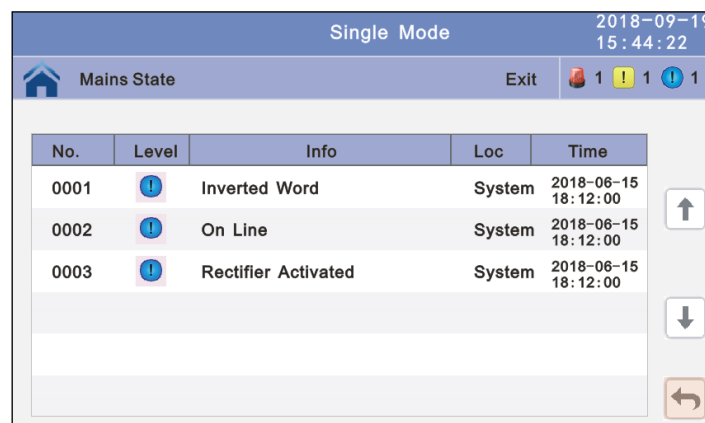

Fig. 4-13 Alarm/History submenu

4.1.3.3 Buzzer submenu

Click the buzzer mute then the buzzer will mute and the red block will change to red (Fig. 4-14), if the buzzer is on, then click the block buzzer will on and the block will change to green (Fig. 4-15).

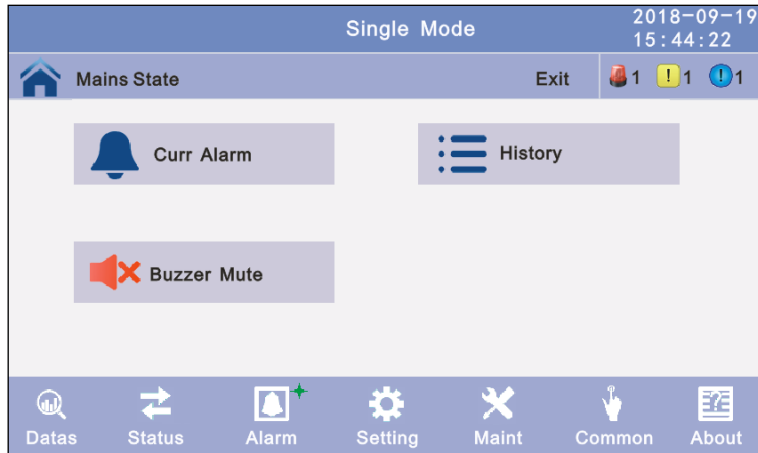

Fig. 4-14 Alarm/Buzzer mute submenu

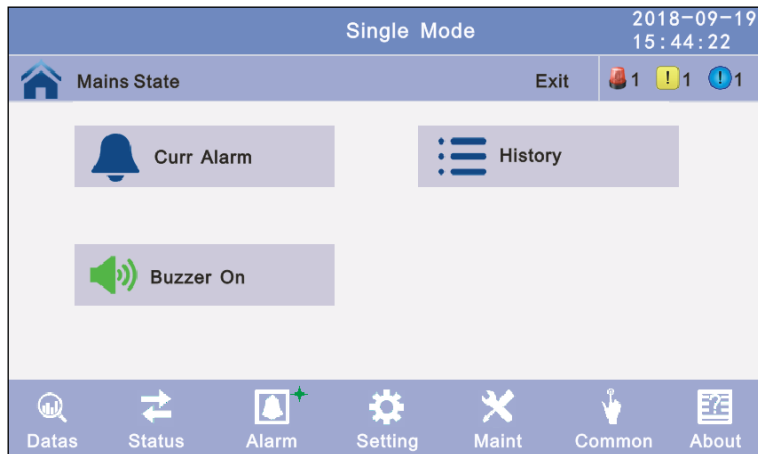

Fig. 4-15 Alarm/Buzzer on submenu

4.1.4 Setting menu

There are two levels, the basic setting for user settings, advanced setting for technical personnel, please contact the relevant technical personnel to enter advanced settings (Fig. 4-16).

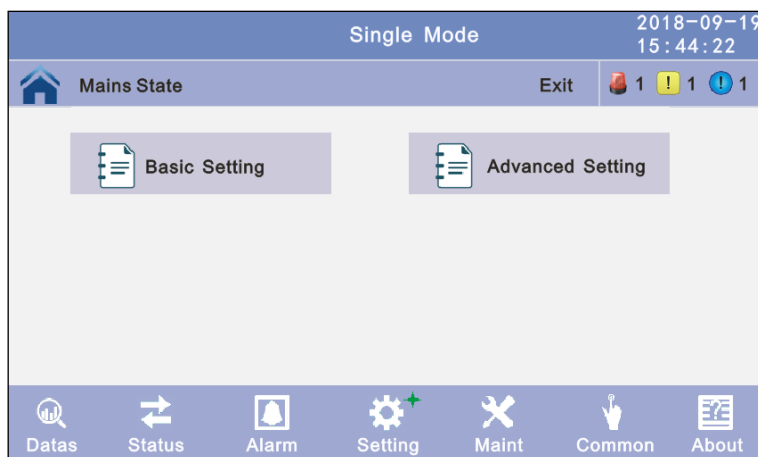

Fig. 4-16 Settings menu

4.1.4.1 Basic Setting submenu

Click basic setting (Fig. 4-19) and enter by input the correct password (Fig. 4-17 and Fig. 4-18).

User password is “111111” for Basic setting.

Admin password is needed for Advanced settings. Contact ZIGOR .

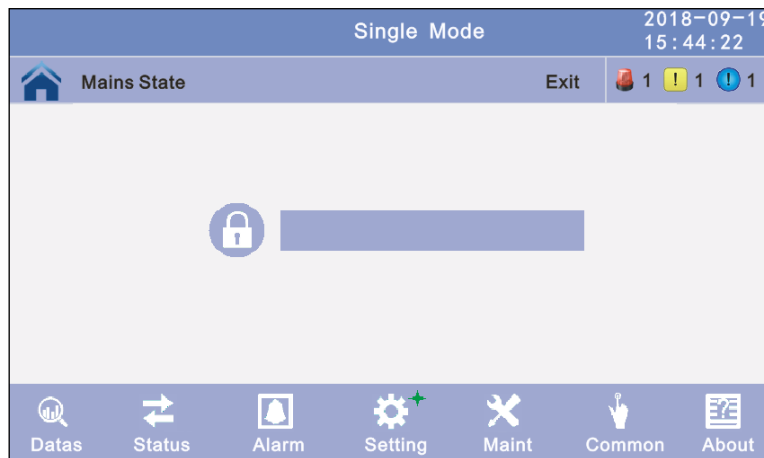

Fig. 4-17 Window to introduce the password

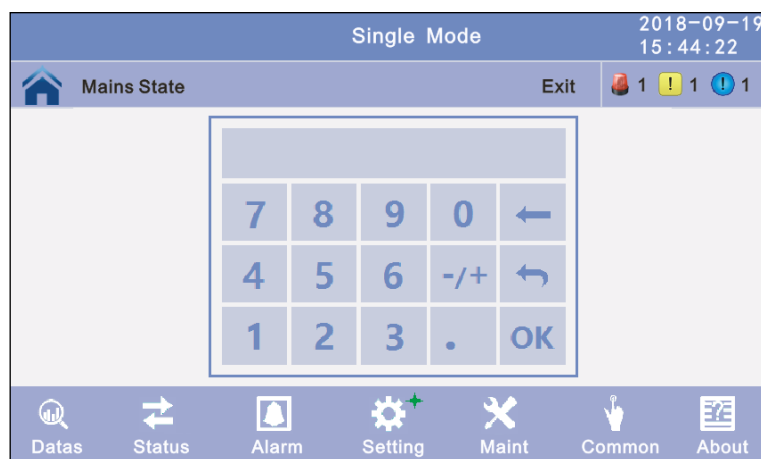

Fig. 4-18 Keyboard to introduce the password

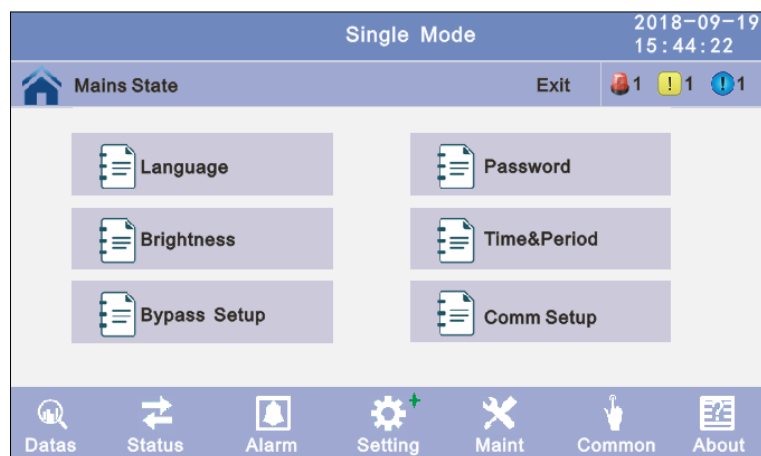

Fig. 4-19 Settings/Basic Settings submenu

- Language submenu

Click the language block witch you want and click the save configuration block to save (Fig. 4-20).



Fig. 4-20 Settings/Basic Settings/Language submenu

- Password submenu

Click password block enter user password setting page, input old password and new password, then click save confirm to save the change (Fig. 4-21). Password format is six numbers.

- o Password lock time submenu: When LCD is not touched, it needs to re login when the setting value is set, click left or right block to change the value.

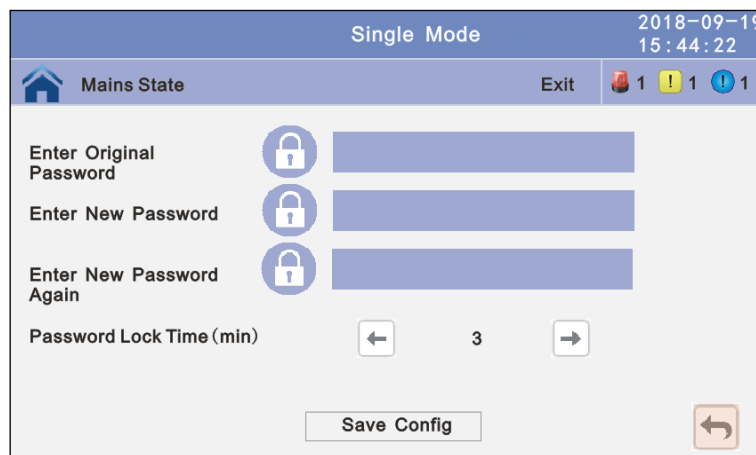

Fig. 4-21 Settings/ Basic Settings/Password submenu

- Brightness and backlight time submenu

Click the block to change value (Fig. 4-22).

- o Brightness: Click the text to input new value and click the save configuration block to save. Value range is 1~63, default value is 63. Click return to return to the previous window, click home page to return to the main page
- o Backlight Time: LCD backlight delay time, click the text to input new value and click save config block to save. Value range is 1~255, default value is 60.



Fig. 4-22 Settings/Basic Settings/Brightness and Backlight Time submenu

- Date and time setting submenu

Click the text to select other value or input new value and click save configuration block to save (Fig. 4-23).

- Date *Format*: Have 3 formats.
- Date : current date.
- Time: current time.

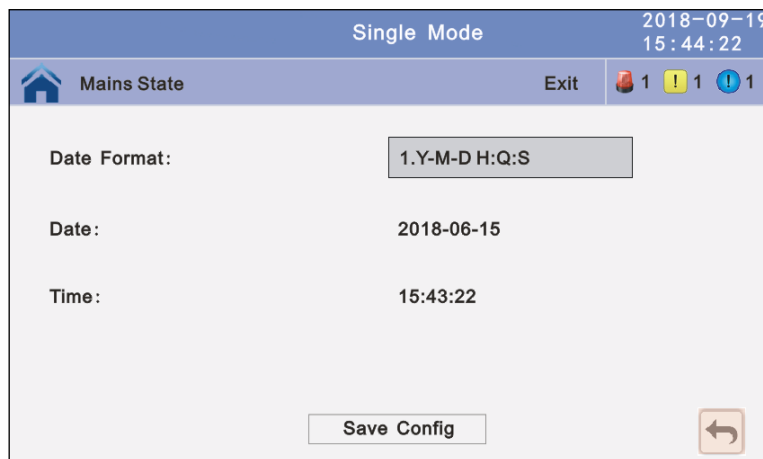

Fig. 4-23 Settings/Basic Settings/Date and Time submenu

- Communication setting submenu (MODBUS RTU)

Click the text to select other value or input new value and click save configuration block to save (Fig. 4-24).

- RS485 *Address*: UPS communication ID, address range is 1~15, default is 1.
- RS485 *Baud Rate*: 2400, 4800, 9600, 14400, 19200, default is 9600.

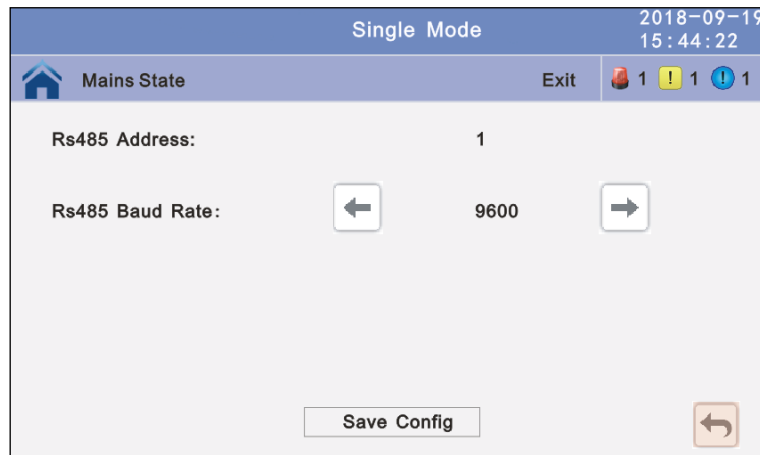

Fig. 4-24 Settings/Basic Settings/Communications submenu

- Bypass settings submenu

The parameters the user can set for the bypass are (Fig. 4-25):

- Bypass *Volt Prot Lower Limit*: When the difference between the bypass voltage and the rated voltage exceeds the lower threshold for the bypass voltage, the system determines that the bypass voltage is abnormal and that the bypass is unavailable. The value can be -10%, -15%, -20%, -30%, -45%.. The default value is - 45%.
- Bypass *Volt Prot Limit*: When the difference between the bypass voltage and the rated voltage exceeds the upper threshold for the bypass voltage, the system determines that the bypass voltage is not normal and that the bypass is unavailable.

NOTE:

- When the voltage level is 380 V, the value range is 10%, 15%, 20%, and 25% (default).
- When the voltage level is 400 V, the value range is 10%, 15%, and 20% (default).
- When the voltage level is 415 V, the value range is 10% and 15%(default).
- Bypass freq. tracking range: When the difference between the bypass input frequency and the rated frequency is greater than this value, the system determines that the bypass frequency is not normal, and that the bypass is unavailable. The value range is 1%, 2%, 4%, 5%, 10% (default).

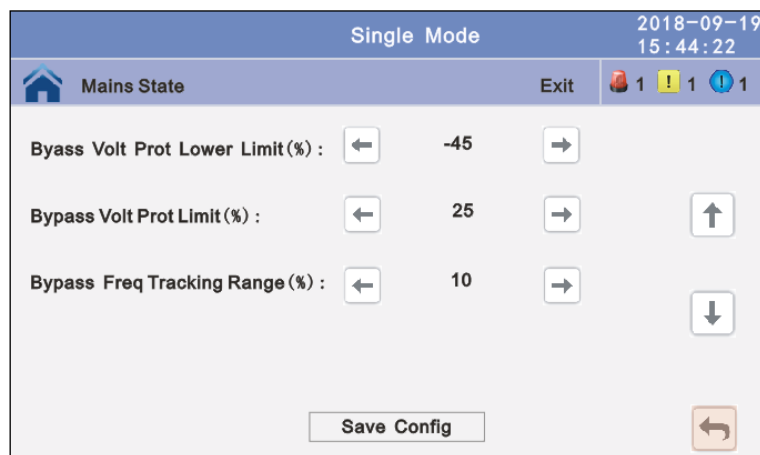

Fig. 4-25 Settings/Basic Settings/Bypass submenu

4.1.4.2 Advanced Setting submenu

Click advanced setting, enter by input the correct password (Fig. 4-26).

WARNING
This operation is recommended to be operated by professionals, or under the guidance of professionals.

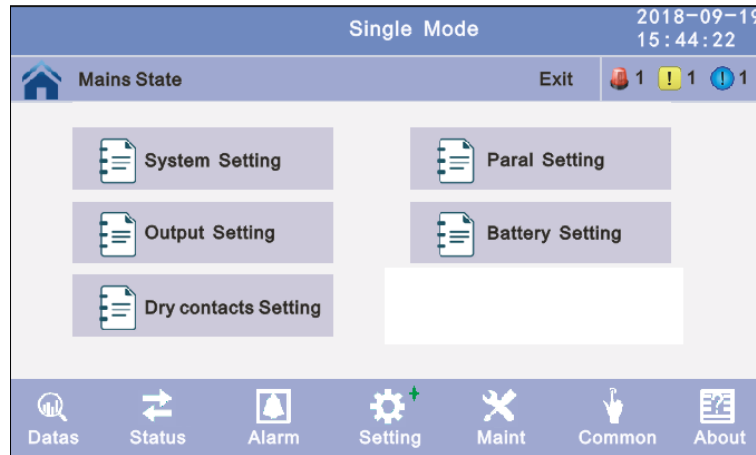

Fig. 4-26 Settings/Advanced Settings submenu

- System setting submenu

Click the text to select other value or input new value and click save configuration block to save (Fig. 4-27, Fig. 4-28, Fig. 4-29 and Fig. 4-30).

- Working *Mode*: Select the work mode of UPS, work mode: Single mode, Parallel mode, ECO mode.
- Auto *Turn-on*. Select the UPS start logic, Enable: UPS start inverter output automatic, Disable: No output.
- Alternate *Cycles*: Select the cycles after set the UPS work mode to Master or Slave. The value can be 1-6, default value: 1

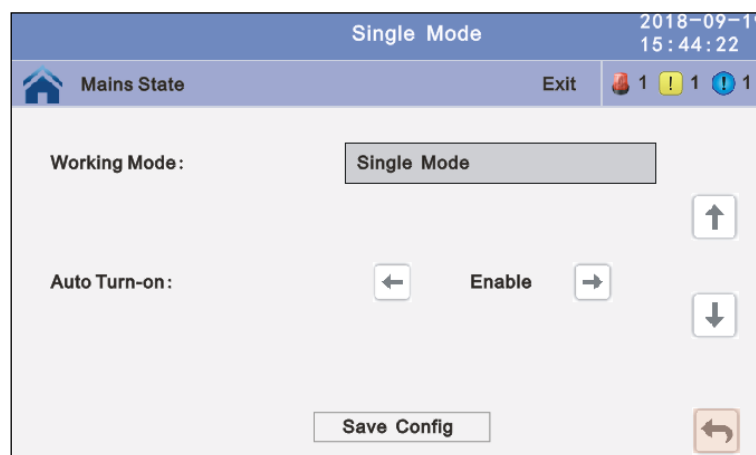

Fig. 4-27 Settings/Advanced Settings/System Setting (1) submenu

- *Freq Conv Mode*: Frequency conversion mode, enable: output frequency set 50Hz or 60Hz, input frequency is 60Hz or 50Hz, UPS no alarm not battery and bypass abnormal. Default is Disable.
- *LBS mode*: setting value: LBS disable, LBS master, LBS slave. Default is LBS disable.

- *Bypass rate tracking rate*: Inverter frequency tracking to bypass frequency rate. The value range is 0.5~2, and is 1 by default.

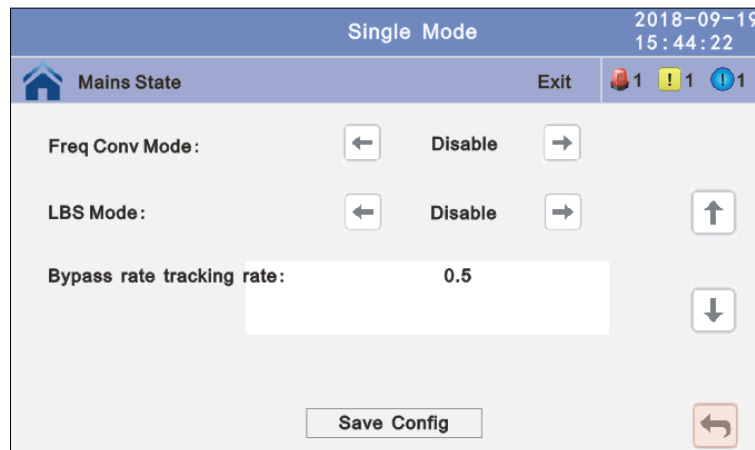

Fig. 4-28 Settings/Advanced Settings/System Setting (2) submenu

- *SCROver Temp Power Supply*: Specifies whether to start bypass mode when over temperature occurs. The default value is Enable.
- *Power Walk in*: this enables the UPS to control the interval that each module transfers from battery mode to normal mode, which reduces the impact on the generator or power grid. The value can be 1~20, default value is 1.

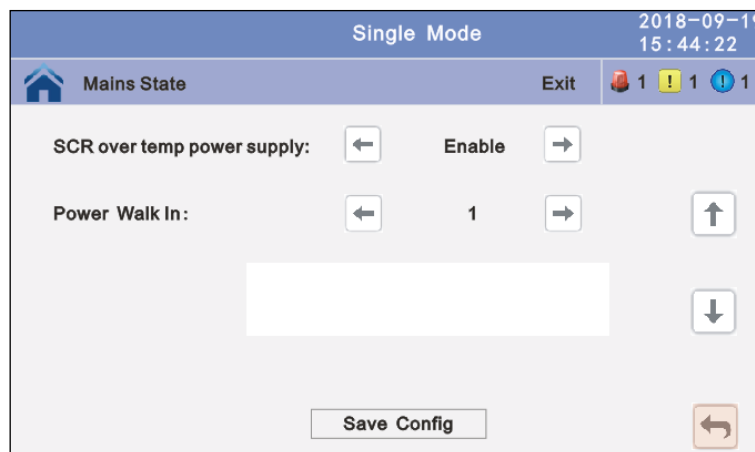

Fig. 4-29 Settings/Advanced Settings/System Setting (3) submenu

- *Aging Load Rate*: The value can be 18~100%, default value: 60%
- *Bypass Switches Limit*: Cross currents occur during the transfer between bypass mode and normal mode, which impacts the system. This parameter specifies the number of transfers between bypass mode and normal mode within 1 hour, which ensures system security. The value can be 3 to 10, and is 10 by default.
- *Temp Sensor Switch*: Temperature sensor compensation switch, when need to connect battery temperature sensor, please change the value to enable.
- *Temp Sensor Select*: Temperature sensor type select. Has two types: NTC and RS485. NTC for single and short distance. RS485 for multiple and far distance.



Fig. 4-30 Settings/Advanced Settings/System Setting (4) submenu

- Parallel setting submenu (Fig. 4-31)
 - Paral *Operation ID*: Parallel operation ID, must modify the ID after set work mode to parallel mode. The value can be 1~6, default value is 1.
 - Cabinet *Paral Basic Units*: Parallel cabinet number, must modify the total parallel cabinet number after set work mode to parallel mode. The value can be 2~6, default value is 2.
 - Cabinet *Paral Redund Units*: Parallel redundancy cabinet number, can modify the redundancy cabinet number after set work mode to parallel mode. The value can be 0~5, default value is 0.

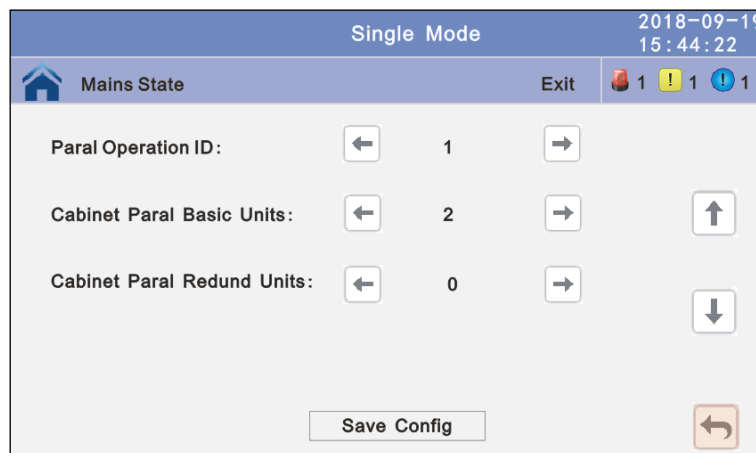

Fig. 4-31 Settings/Advanced Settings/Parallel Setting submenu

- Output setting submenu (Fig. 4-32)
 - Output *Freq*: Output frequency, the value can be 50Hz or 60Hz.
 - Output *Volt Level*: Output voltage level, the value can be 220V, 230V, 240V.
 - Output *Ivn Volt Regu*: Inverter voltage regulated, the value can be -5%~0~+5%, step is 0.5%, default value: 0.

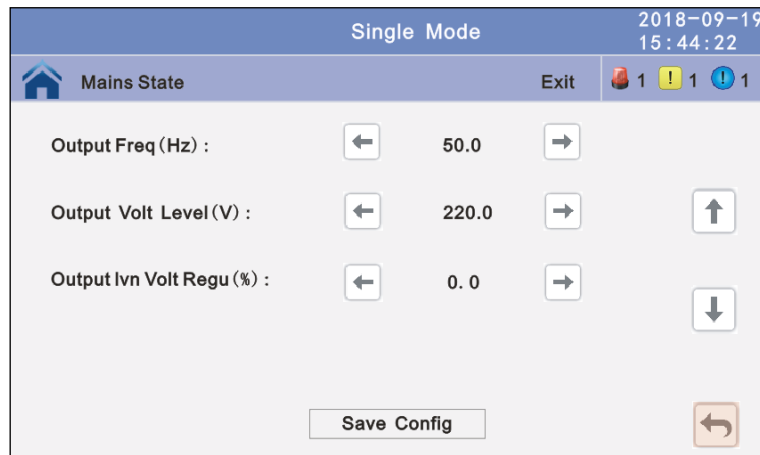

Fig. 4-32 Settings/Advanced Settings/Output submenu

- Battery setting submenu (Fig. 4-33, Fig. 4-34 and Fig. 4-35)
 - Battery *Group*. Must modify the number to actual configuration, The value can be 1-8, default value is 1.
 - Battery *number*. Must modify the number to actual configuration, The value can be 30-50, default value is 36.
 - Single *Battery Capability*. Must modify the value to actual configuration, The value can be 7-2000.

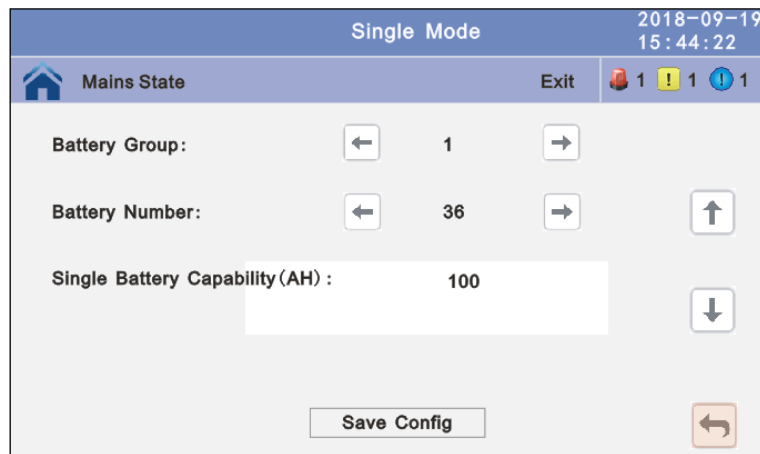

Fig. 4-33 Settings/Advanced Settings/Battery (1) submenu

- *Chg.cur.limiting coef.*: The charging current limit is a multiple of the battery capacity. The value can be 0,05 – 0,15, and is 0,1 by default.
- *Cell float voltage*: The float voltage value can be 2,23 - 2,30 V/cell, and is 2,25 V/cell by default.
- *Cell boost voltage*: The battery equalized voltage value can be 2,30 – 2,40 V/cell, and is 2,30 V/cell by default.
- *Aver charging Duration*: boost charge time limit, the value can be 1 – 999min , and is 240 by default

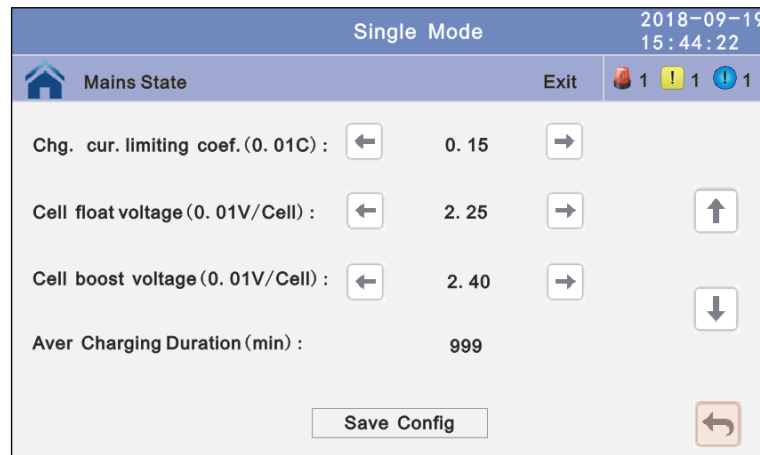

Fig. 4-34 Settings/Advanced Settings/Battery (2) submenu

- *EOD Battery Volt*: End of discharge voltage. The value can be 1,60 ~ 1,90, and is 1,80 by default.
- *Float Temp Compens Coeff*: Modify the voltage of compensation after enable the switch. The value can be 0,001 ~ 0,007/cell, and is 0,003 by default.
- *Boost Charge Setting*: Boost charge disable or enable, and is enabled by default.
- *No Battery Warning*: Can be no warning when no batter after set disable, and is enabled by default.

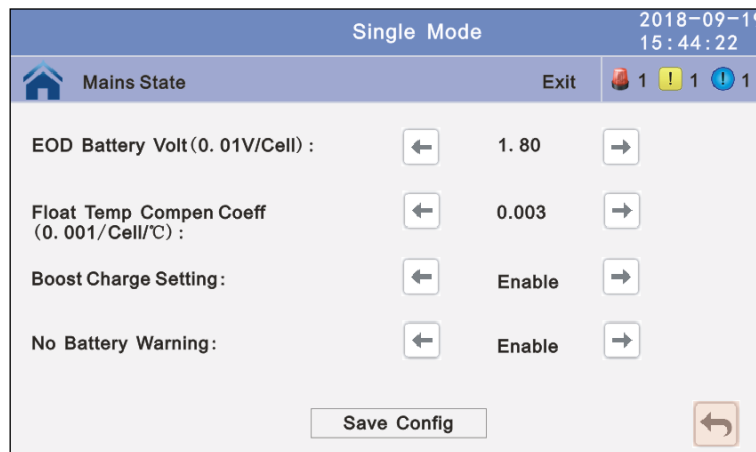

Fig. 4-35 Settings/Advanced Settings/Battery (3) submenu

- Dry contact setting submenu (Fig. 4-36)
 - *External Battery Switch*: Enable or disable battery breaker connection detection. The default value is Disable.
 - *Battery abnormal BCB trip*: Enable or disable BCB trip single output. The default value is Disable.
 - *Bypass Feedback*: Enable or disable bypass feedback output. The default value is Disable.
 - *External Maint. breaker*: Enable or disable external maintenance breaker connection detection. The default value is Disable

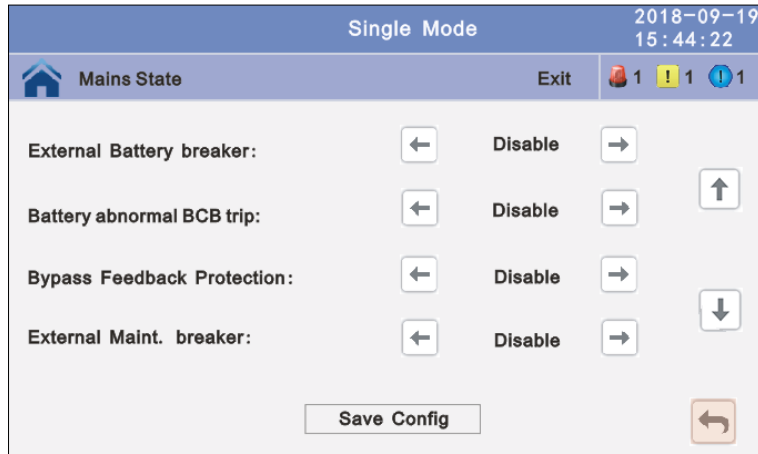

Fig. 4-36 Settings/Advanced Settings/Dry contacts submenu

4.1.5 Maint menu

In this menu the History can be downloaded, the touch correction adjusted and done a battery self-test (Fig. 4-37).

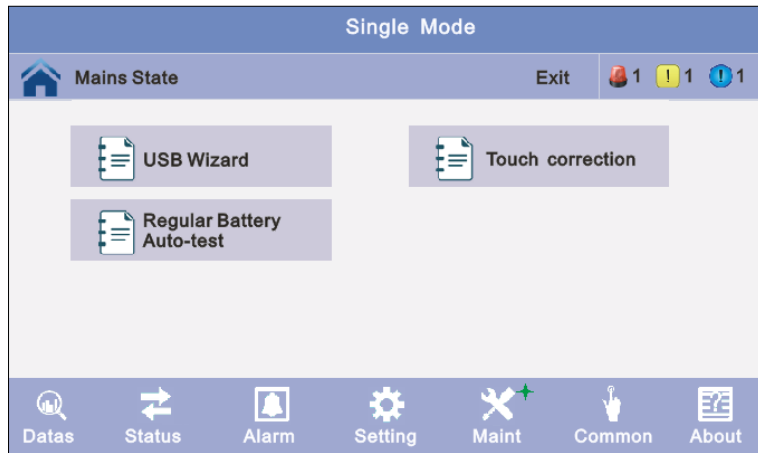

Fig. 4-37 Maint menu

4.1.5.1 USB Wizard submenu

This submenu provides the History Output, downloads history and sets the setting record by USB (Fig. 4-38).

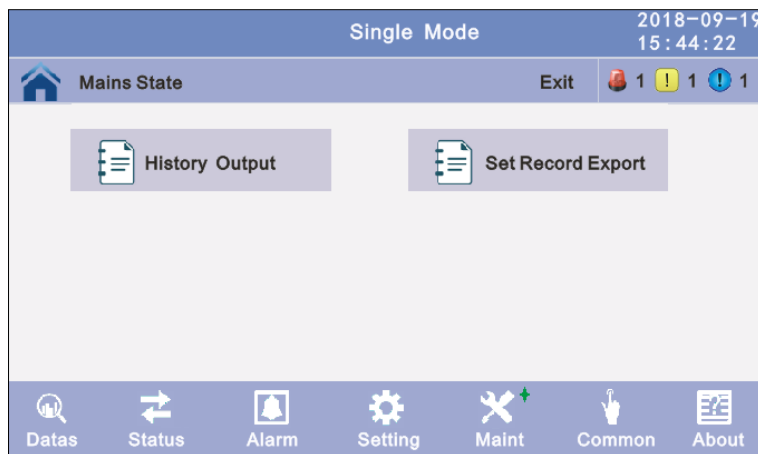

Fig. 4-38 Maint/USB Wizard submenu

- Alarm log output submenu (Fig. 4-39)



Fig. 4-39 Maint/USB Wizard/Alarm log output submenu

- Setting log output submenu (Fig. 4-40)



Fig. 4-40 Maint/USB Wizard/Setting log output submenu

4.1.5.2 Battery Self-Check submenu

It can be selected the check by Timing Daily, Timing Weekly. The default value is Timing Self-Check Close (Fig. 4-41).

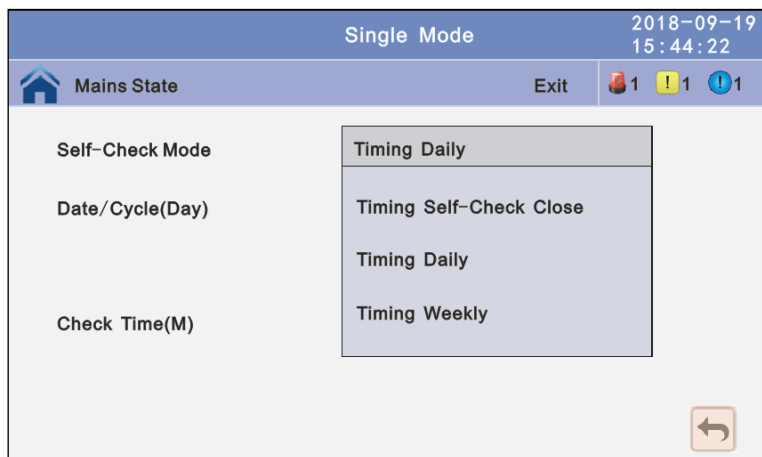

Fig. 4-41 Maint/ Battery Self-Check submenu

- Timing daily

Modify the check date, time and check time (10S (default), 10min, EOD) (Fig. 4-42).

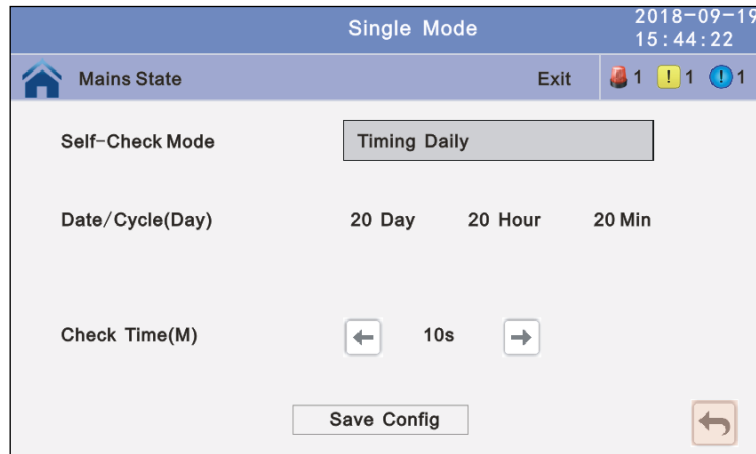

Fig. 4-42 Maint/Battery Self-Check/Timing daily submenu

- Timing weekly

Modify the check date, time and check time (10S (default), 10min, EOD) (Fig. 4-43).

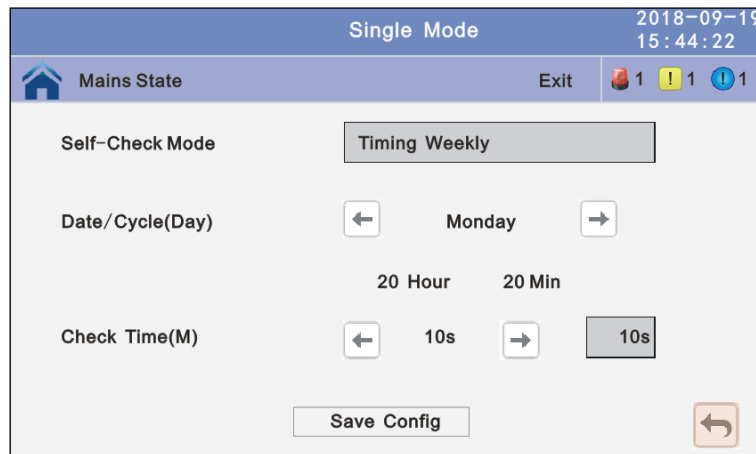

Fig. 4-43 Maint/Battery Self-Check/Timing Weekly submenu

4.1.6 Common menu

Through this menu the inverter can be started-up or switched off (INV ON/OFF), test the battery and clear the faults (Fig. 4-44).

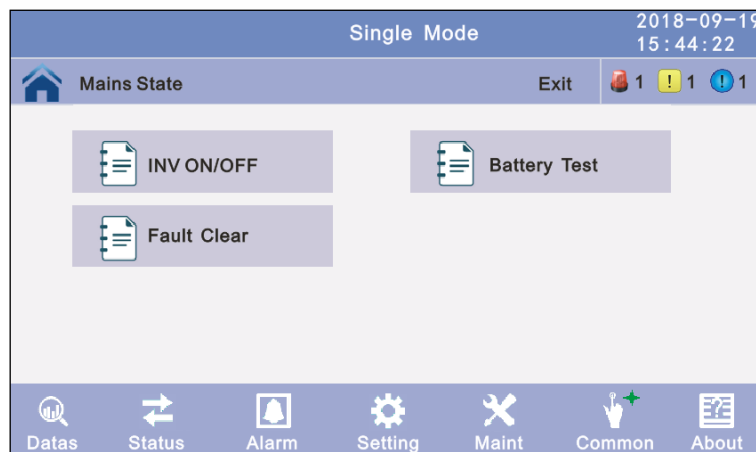

Fig. 4-44 Common menu

4.1.6.1 INV ON/OFF submenu

In this window the inverter can be started-up or switched off (INV ON/OFF) depending on the configuration (Fig. 4-45).

- *Single OFF*: Power OFF local UPS Inverter. (Set to static bypass mode)
- *Single ON*: Power ON local UPS Inverter
- *Parallel OFF*: Power OFF full parallel system UPS (Set to full static bypass mode)
- *Parallel ON*: Power ON full parallel system UPS

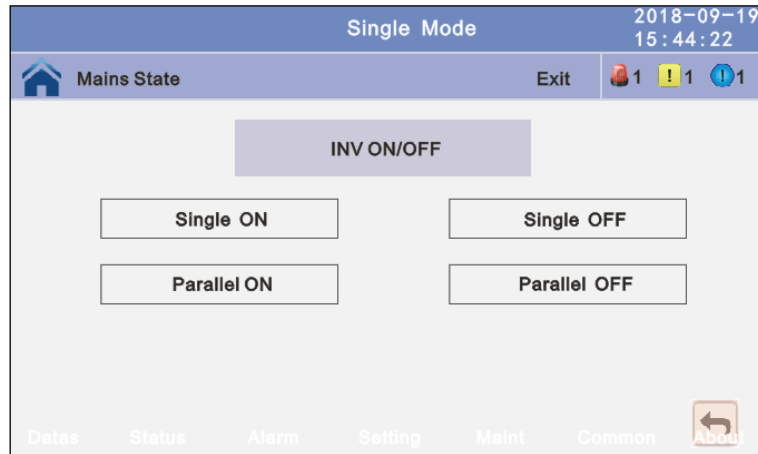

Fig. 4-45 Common/INV ON/OFF submenu

4.1.6.2 Battery Test submenu

To test the battery (Fig. 4-46). It can be tested:

- *10S*: battery test for 10s
- *10min*: battery test for 10min
- *EOD*: battery test to EOD
- *-10%*: battery test down 10% capability.

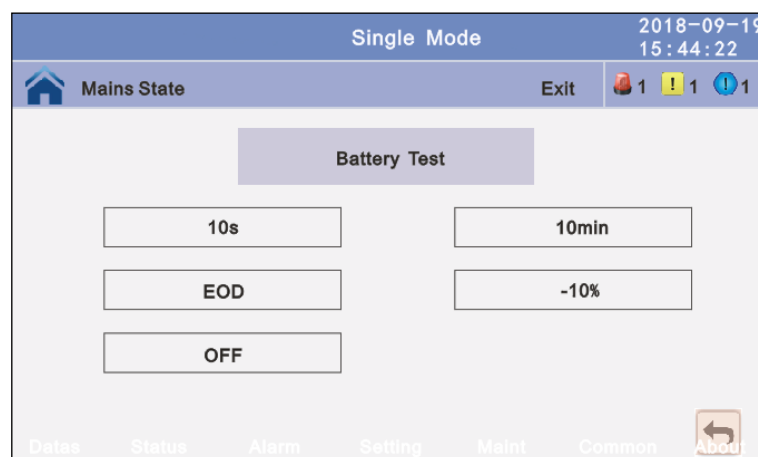

Fig. 4-46 Common/Battery Test submenu

4.1.6.3 Fault Clear submenu

Clear the current fault (not for all faults) (Fig. 4-47).

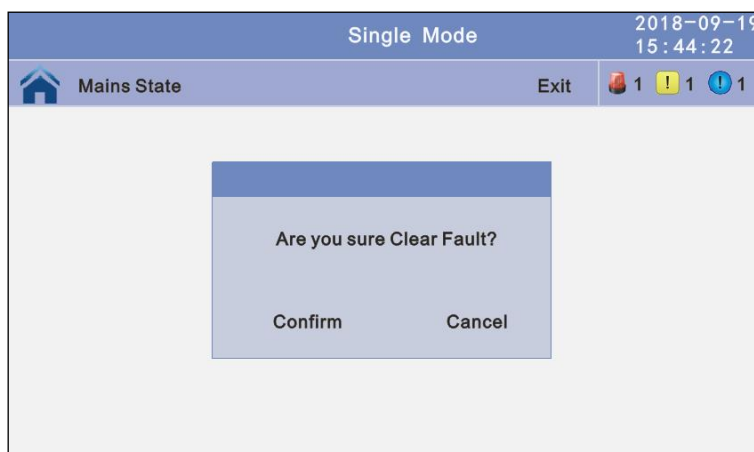

Fig. 4-47 Common/Fault Clear submenu

4.1.7 About Menu

It shows the software version Monitor and LCD software version (Fig. 4-48).

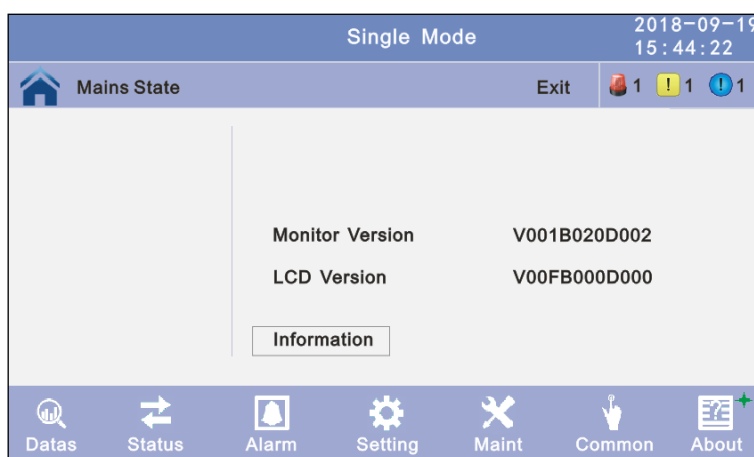

Fig. 4-48 About menu

4.2 Events and status list

This section lists the event and alarm messages that the UPS might display. The messages are listed in alphabetical order. This section is listed with each alarm message to help you troubleshoot problems.

4.2.1 Operational Status and Mode(s)

N.º	UPS STATUS INDICATIONS	LED			
		FAULT	BYPASS	BATTERY	INVERTER
1	Initialized	Extinguish	Extinguish	Extinguish	Extinguish
2	Standby Mode	Extinguish	Extinguish	X	Extinguish
3	No Output	Extinguish	Extinguish	X	Extinguish
4	Bypass Mode	Extinguish	Light	X	Extinguish
5	Utility Mode	Extinguish	Extinguish	X	Light
6	Battery Mode	Extinguish	Extinguish	Light	Extinguish
7	Battery Self-diagnostics	Extinguish	Extinguish	Light	Extinguish
8	Inverter is starting up	Extinguish	X	X	Extinguish
9	ECO Mode	Extinguish	X	X	X
10	EPO Mode	Light	Extinguish	X	Extinguish
11	Maintenance Bypass Mode	Extinguish	Extinguish	Extinguish	Extinguish
12	Fault Mode	Light	X	X	X

Table 4-1 Status and modes

NOTE: "X" means it is determined by other conditions

4.2.2 Fault Information

N.º	FAULT CODE	UPS ALARM WARNING	BUZZER	LED
1	002	REC Over Temperature	Buzzer	Fault LED lit
2	003	REC par. cable Fault	Twice per second	Fault LED lit
3	004	REC Over Current	Twice per second	Fault LED lit
4	005	REC Power Fault	Beep continuously	Fault LED lit
5	007	Input SCR Fault	Beep continuously	Fault LED lit
6	00A	Battery SCR Fault	Beep continuously	Fault LED lit
7	00C	Charge SCR Fault	Beep continuously	Fault LED lit
8	00E	Fan Fault	Beep continuously	Fault LED lit
9	011	Fan Power fault	Beep continuously	Fault LED lit
10	012	Charger Over Temp.	Beep continuously	Fault LED lit
11	013	Soft Start Failed	Beep continuously	Fault LED lit

12	014	BAT Charger Fault	Beep continuously	Fault LED lit
13	016	REC Comm. Fault	Beep continuously	Fault LED blinking
14	019	REC Initializes Fault	Once per 2 seconds	Fault LED lit
15	01D	Unit insert fault	Beep continuously	Fault LED lit
16	063		Once per 2 seconds	Fault LED lit
17	01E	Rectifier Fault	Once per 2 seconds	Fault LED lit
18	041	Inverter Fault	Beep continuously	Fault LED lit
19	044	INV IGBT SHORT	Beep continuously	Fault LED lit
20	047	Inverter relay Short	Beep continuously	Fault LED lit
21	04A	Inverter relay Broken	Beep continuously	Fault LED lit
22	04D	INV par. cable Fault	Beep continuously	Fault LED lit
23	051	Output Short Circuit	Twice per second	Fault LED blinking
24	054	INV Comm. Fault	Once per second	Fault LED blinking
25	057	INV Initializes Fault	Once per 2 seconds	Fault LED lit
26	05A	INV self-test Fault	Beep continuously	Fault LED lit
27	05E	DC Component Fault	Beep continuously	Fault LED lit
28	061	DC bus abnormal	Once per 2 seconds	Fault LED lit
29	064	INV DSP Power Fault	Beep continuously	Fault LED lit
30	067	INV Over Temperature	Beep continuously	Fault LED lit
31	068	Load Sharing Fault	Twice per second	Fault LED lit
32	06A	Cabinet mode Fault	Twice per second	Fault LED lit
33	06B	Fuse Broken	Beep continuously	Fault LED lit
34	081	Par. cable Fault	Beep continuously	Fault LED lit
35	086	ECU Insert Fault	Twice per second	Fault LED lit
36	088	ECU Power Fault	Once per 2 seconds	Fault LED lit
37	08B	ECU Comm. Fault	Beep continuously	Fault LED lit
38	08D	ECU Initializes Fault	Beep continuously	Fault LED blinking
39	091	Bypass SCR Broken	Once per 2 seconds	Fault LED lit
40	0C2		Beep continuously	Fault LED lit
41	094	Bypass SCR short	Beep continuously	Fault LED lit
42	0C5		Beep continuously	Fault LED lit
43	097	BPS Over Temperature	Beep continuously	Fault LED lit
44	0CF		Beep continuously	Fault LED lit
45	09A	Output CT Reverse	Beep continuously	Fault LED lit
46	09D	Bypass Feedback Fault	Beep continuously	Fault LED lit

Table 4-2 Faults list

4.2.3 Alarm Information

N.º	ALARM CODE	UPS ALARM WARNING	BUZZER	LED
1	103	Battery Over Voltage	Once per second	BATTERY LED blinking
2	104	BAT Low Pre-warning	Once per second	BATTERY LED blinking
3	105	Battery Reverse	Twice per second	BATTERY LED blinking
4	106	Battery EOD	Once per second	BATTERY LED blinking
5	107	Battery Voltage low	Once per second	BATTERY LED blinking
6	108	No Battery	Once per second	BATTERY LED blinking
7	109	Input Phase Reverse	Once per second	INVERTER LED blinking
8	10A	Input N-Line lost	Twice per second	INVERTER LED blinking
9	10B	Mains Freq. Abnormal	Once per 2 seconds	INVERTER LED blinking
10	10C	Mains Volt. Abnormal	Once per 2 seconds	INVERTER LED blinking
11	10D	REC Comm. Error	Once per 2 seconds	INVERTER LED blinking
12	10E	Mains input lost	Once per 2 seconds	
13	10F	Set Data Err.	Once per 2 seconds	FAULT LED blinking
14	121	INV Par. cable abnormal	Once per 2 seconds	FAULT LED blinking
15	125	INV Overload	Once per 2 seconds	INVERTER LED blinking
16	126	INV not synchronized	Beep continuously	INVERTER LED blinking
17	12A	INV Set Data Err	Once per 2 seconds	FAULT LED blinking
18	129	INV Comm. Error	Once per 2 seconds	FAULT LED blinking
19	141	Bypass Switch to Num	Once per 2 seconds	BYPASS LED blinking
20	142	Unit quantity mismatch	Once per 2 seconds	FAULT LED blinking
21	143	Parallel Overload	Once per 2 seconds	INVERTER LED blinking
22	144	Bypass Overload	Once per 2 seconds	BYPASS LED blinking
23	145	Maint. Switch Misuse	Once per 2 seconds	FAULT LED blinking
24	146	ECU Comm. Error	Once per 2 seconds	FAULT LED blinking
25	147	Par. cable abnormal	Once per 2 seconds	FAULT LED blinking
26	14B	ECU Par. cable abnormal	Once per 2 seconds	FAULT LED blinking

27	14C	ECU Abnormal	Once per 2 seconds	FAULT LED blinking
28	14E	BPS Phase Reversed	Once per second	BYPASS LED blinking
29	162		Once per second	BYPASS LED blinking
30	14F	BPS Unable To Trace	Once per 2 seconds	BYPASS LED blinking
31	163		Once per 2 seconds	BYPASS LED blinking
32	150	BPS Not Available	Once per second	BYPASS LED blinking
33	164		Once per second	BYPASS LED blinking
34	151	Ecu Set Data Err	Once per 2 seconds	FAULT LED blinking

Table 4-3 Alarms list

5 INSTALLATION

5.1 Unpack checking

Don't lean the UPS when moving it out from the packaging.

Check the appearance to see if the UPS is damaged during transportation, do not switch on the UPS if any damaged is found and please contact the dealer.

Check the accessories according to the packing list and contact the dealer if any parts missing.

From then on, the customer will have 24 hours to make any claim under guarantee for any anomaly in the amount or quality of the products received, providing details of the material received in bad condition after reporting this circumstance on the forwarding agent's delivery note on reception.

Should the customer not report any defect within 24 hours, it will be understood that he has accepted delivery of the unit.

5.2 Mechanical installation



WARNING

Consider for the convenience of operation and maintenance, the space in front and back of the cabinet should be left at least 100cm and 80cm respectively when installing the cabinet.

- Please place the UPS in a clean, stable environment, avoid the vibration, dust, humidity, flammable gas and liquid, corrosive objects. To avoid from high room temperature, a system of room extractor fans is recommended to be installed. Optional air filters are available if the UPS operates in a dusty environment.
- The environment temperature around the UPS should keep in a range of 0°C ~ 40°C. If the environment temperature exceeds 40 °C, the rated load capacity should be reduced by 12% per 5 °C. The max temperature can't be higher than 50 °C.
- If the UPS is dismantled under low temperature, it might be in a condensing condition. The UPS can't be installed unless the internal and external of the equipment is fully dry. Otherwise, there will be in danger of electric shock.
- Batteries should be mounted in an environment where the temperature is within the required specs. Temperature is a major factor in determining battery life and capacity. In a normal installation, the battery temperature is maintained between 15 °C and 25 °C. Keep batteries away from heat sources or main air ventilation area, etc.



WARNING

Typical battery performance data are quoted for an operating temperature between 20°C and 25°C. Operating it above this range will reduce the battery life while operation below this range will reduce the battery capacity.

- Should the equipment not be installed immediately it must be stored in a room so as to protect it against excessive humidity and or heat sources.



WARNING

An unused battery must be recharged every 6months Temporarily connecting the UPS to a suitable AC supply mains and activating it for the time required for recharging the batteries.

- The highest altitude that UPS may work normally with full load is 1500 meters. The load capacity should be reduced when this UPS is installed in place whose altitude is higher than 1500 meters, shown as the Table 5-1:

(Load coefficient equals max load in high altitude place divided by nominal power of the UPS)

ALTITUDE (m)	1500	2000	2500	3000	3500	4000	4500	5000
LOAD COEFICIENT	100%	95 %	90 %	85 %	80 %	75 %	70 %	65 %

Table 5-1 Load coefficient

- The UPS cooling is depending on fan, so it should be kept in good air ventilation area. There are many ventilation holes on the front and rear, so they should not be blocked by any exotic obstacles.

5.3 Electrical installation

5.3.1 External Protective Devices

For safety reasons, it is necessary to install, external circuit breaker at the input A.C. supply and the battery. This chapter provides guidelines for qualified installers that must have the knowledge of local wiring practices for the equipment to be installed.

- External Battery

The UPS and its associated batteries are protected against the effect of over-current through a DC compatible thermo-magnetic circuit-breaker (or a set of fuses) located close to the battery.

- UPS Output

Any external distribution board used for load distribution shall be fitted with protective devices that may avoid the risk of UPS overloaded.

- Over-current

Protection device shall be installed at the distribution panel of the incoming main supply. It may identify the power cables current capacity as well as the overload capacity of the system.



WARNING

Select a thermomagnetic circuit-breaker with an IEC 60947-2 trip curve C (normal) for 125% of the current as listed below.

5.4 Connection of Power Cables

The cable design shall comply with the voltages and currents provided in this section, Kindly follow local wiring practices and take into consideration the environmental conditions (temperature and physical support media).



WARNING

Upon starting, please ensure that you are aware of the location and operation of the external isolators which are connected to the UPS input/bypass supply of the mains distribution panel. Check to see if these supplies are electrically isolated. Post necessary warning signs to prevent any inadvertent operation.

5.4.1 Recommended cross-sectional areas for power cables

- When selecting, connecting, and routing power cables, follow local safety regulations and rules.
- If external conditions such as cable layout or ambient temperatures change, perform verification in accordance with the IEC-60364-5-52 or local regulations.
- If the rated voltage is 400 V, multiply the currents by 0,95. If the rated voltage is 415 V, multiply the currents by 0,92.
- If primary loads are non-linear loads, increase the cross-sectional areas of neutral wires 1,5–1,7 times.
- The nominal battery discharge current refers to the current of forty 12 V batteries at 480V in standard configuration.
- The maximum battery discharge current refers to the current when forty 12 V batteries in standard configuration, that is, two hundred and forty 2 V battery cells (1.67 V/cell), stop discharging.
- The battery cable specifications are selected based on 40 batteries by default and compatible with application scenarios with 30–50 batteries.
- When the mains input and bypass input share a power source, configure both types of input power cables as mains input power cables. The cables listed in Table are used only when the following requirements are met:
 - Routing mode: Routing the cables over the cable ladder or bracket in a single layer (IEC60364-5-52 middle E).
 - The ambient temperature is 30°C.
 - The AC voltage loss is less than 3%, and the DC voltage loss is less than 1%.
 - 90°C copper flexible cable.
 - The length of the AC power cables of a UPS is no longer than 30 m and DC power cables no longer than 50 m.

UPS CABINET	CABLE DIMENSION			
	AC Input (mm ²)	AC Output (mm ²)	DC Input (mm ²)	Ground (mm ²)
50 kVA	25	16	50	16
60 kVA	35	35	50	25
80 kVA	50	50	70	35
100 kVA	70	50	120	35
120 kVA	95	70	150	50
150 kVA	120	95	185	70
180 kVA	150	120	120*2	95
200 kVA	150	120	120* 2	95

Table 5-2 Cross-sectional areas for power cables

5.4.2 Power cable connector requirements

MODEL	CONNECTOR	CONNECTION MODE	BOLT TYPE	BOLT HOLE DIAMETER	TORQUE
50 – 60 kVA	Mains input connector	Crimped OT terminals	M8	9mm	20Nm
	Bypass input connector	Crimped OT terminals	M8	9mm	20Nm
	Battery input connector	Crimped OT terminals	M10	11mm	26Nm
	Output connector	Crimped OT terminals	M8	9mm	20Nm
	Grounding connector	Crimped OT terminals	M8	9mm	20Nm
80 - 120kVA	Mains input connector	Crimped OT terminals	M10	11mm	26Nm
	Bypass input connector	Crimped OT terminals	M10	11mm	26Nm
	Battery input connector	Crimped OT terminals	M10	11mm	26Nm
	Output connector	Crimped OT terminals	M10	11mm	26Nm
	Grounding connector	Crimped OT terminals	M10	11mm	26Nm
150 – 200 kVA	Mains input connector	Crimped OT terminals	M10	11mm	26Nm
	Bypass input connector	Crimped OT terminals	M10	11mm	26Nm
	Battery input connector	Crimped OT terminals	M10	11mm	26Nm
	Output connector	Crimped OT terminals	M10	11mm	26Nm
	Grounding connector	Crimped OT terminals	M10	11mm	26Nm

Table 5-3 Power cable connectors

5.4.3 Recommended input front-end and output back-end circuit breakers

UPS CAPACITY	COMPONENT	SPECIFICATIONS
50 kVA	Mains input circuit breaker	100A 3P
	Bypass input circuit breaker	100A 3P
	Output circuit breaker	100A 3P
	Battery circuit breaker	160A 3P
60 kVA	Mains input circuit breaker	125A 3P
	Bypass input circuit breaker	125A 3P
	Output circuit breaker	125A 3P
	Battery circuit breaker	200A 3P
80 kVA	Mains input circuit breaker	160A 3P
	Bypass input circuit breaker	160A 3P
	Output circuit breaker	160A 3P
	Battery circuit breaker	250A 3P
100 kVA	Mains input circuit breaker	200A 3P
	Bypass input circuit breaker	200A 3P
	Output circuit breaker	200A 3P
	Battery circuit breaker	320A 3P
120 kVA	Mains input circuit breaker	250A 3P
	Bypass input circuit breaker	250A 3P
	Output circuit breaker	250A 3P
	Battery circuit breaker	400A 3P
150 kVA	Mains input circuit breaker	320A 3P
	Bypass input circuit breaker	320A 3P
	Output circuit breaker	320A 3P
	Battery circuit breaker	500A 3P
180 – 200 kVA	Mains input circuit breaker	400A 3P
	Bypass input circuit breaker	400A 3P
	Output circuit breaker	400A 3P
	Battery circuit breaker	630A 3P

Table 5-4 Input and output switches



WARNING

Protective earth cable: Connect each cabinet to the main ground system. For Grounding connection, follow the shortest route possible.



WARNING

Failure to follow adequate earthing procedures may result in electromagnetic interference or in hazards involving electric shock and fire

5.5 Power cable connection

Once the equipment has been finally positioned and secured, connect the power cables as described in the following procedure.

Verify the UPS is totally isolated from its external power source and also all power isolators of the UPS are open. Check to see if they are electrically isolated, and post any necessary warning signs to prevent their inadvertent operation.

Open the UPS rear panel; Remove the cover of terminals for wiring easily.

5.5.1 Common input connection

50 kVA and 60 kVA

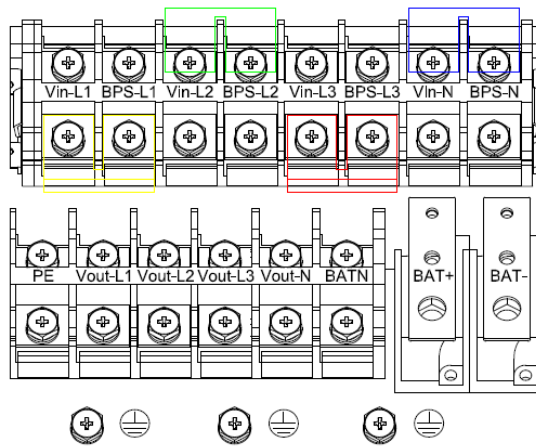

Fig. 5-1 Common input connection 50-60KVA

80 kVA-150 kVA

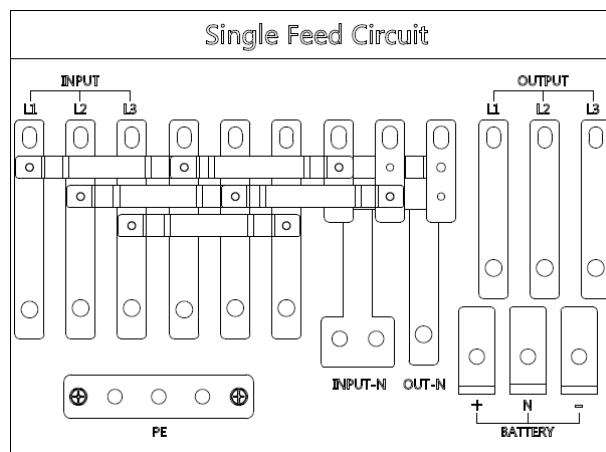

Fig. 5-2 Common input connection 80-150KVA

180 kVA-200 kVA

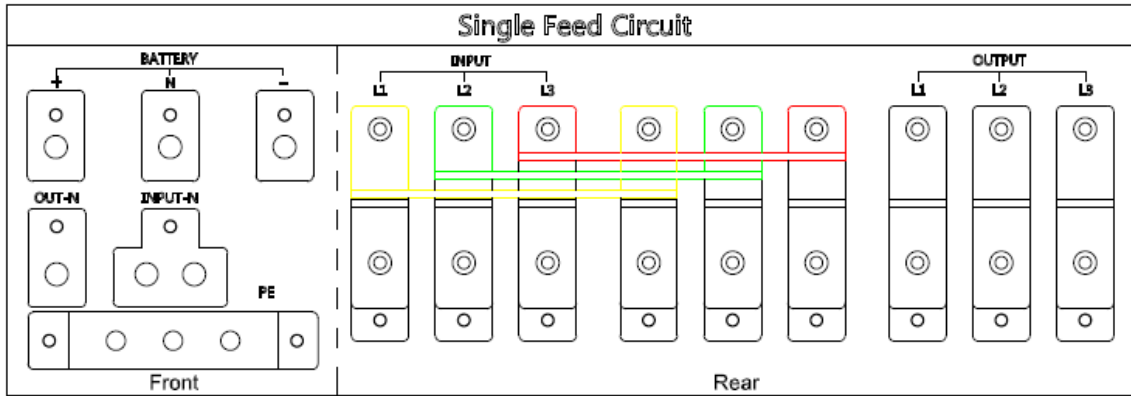

Fig. 5-3 Common input connection 180-200KVA

INPUT PRIMARY INPUT LINE	OUTPUT
Vin-L1: Primary input Phase L1	Vout-L1: Output Phase L1
Vin-L2: Primary input Phase L2	Vout -L2: Output Phase L2
Vin-L3: Primary input Phase L3	Vout -L3: Output Phase L3
Vin-N: Input Neutral for primary and secondary input	Vout -N: Output Neutral
	PE: Grounding
	BAT+: Positive terminal of the batteries string
	BATN: Neutral terminal of the batteries string
	BAT-: Negative terminal of the batteries string

Table 5-5 Common input connections

5.5.2 Dual input connection

50 kVA and 60 kVA

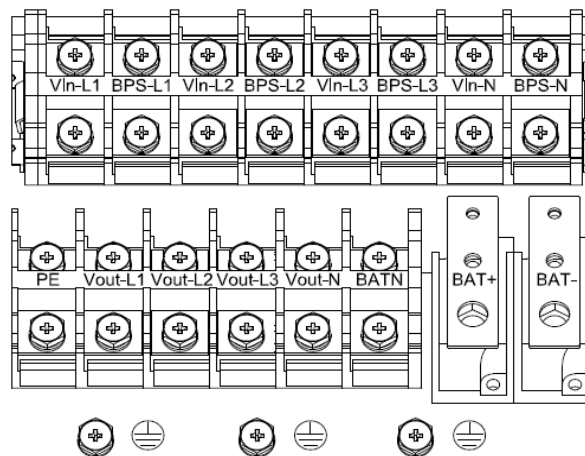

Fig. 5-4 Dual input connection 50-60VA

80 kVA-150 kVA

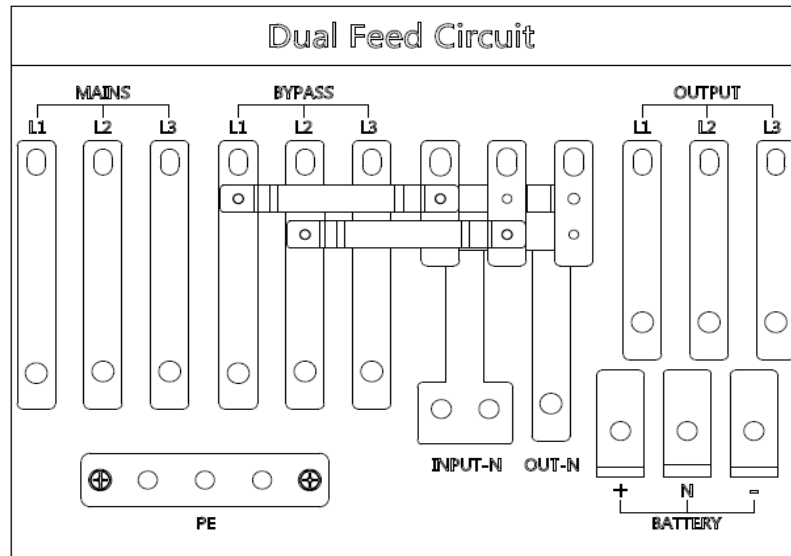

Fig. 5-5 Dual input connection 80-150KVA

180 kVA-200 kVA

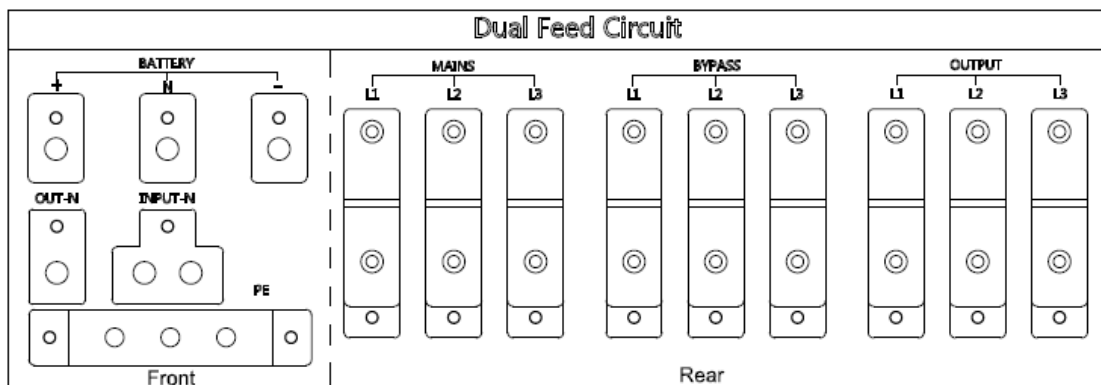

Fig. 5-6 Dual input connection 180-200KVA

MAINS PRIMARY INPUT LINE	OUTPUT
Bypass Secondary/Bypass input line (optional)	Vout-L1: Output Phase L1
Vin-L1: Primary input Phase L1	Vout-L2: Output Phase L2
Vin-L2: Primary input Phase L2	Vout-L3: Output Phase L3
Vin-L3: Primary input Phase L3	Vout-N: Output Neutral
Vin-N: Input Neutral for primary and secondary input	PE: Grounding
BPS-L1: Secondary input Phase L1	BAT+: Positive terminal of the batteries string
BPS-L2: Secondary input Phase L2	BATN: Neutral terminal of the batteries string
BPS-L3: Secondary input Phase L3	BAT-: Negative terminal of the batteries string

Table 5-6 Dual input connections



WARNING

In the case of “Dual input” operation, make sure the copper wire between each input lines have been removed. The AC input and the AC bypass supplies must be referenced to the same neutral point.

In the case of “Dual input” operation, make sure the copper wire between each input lines have been removed. The AC input and the AC bypass supplies must be referenced to the same neutral point.

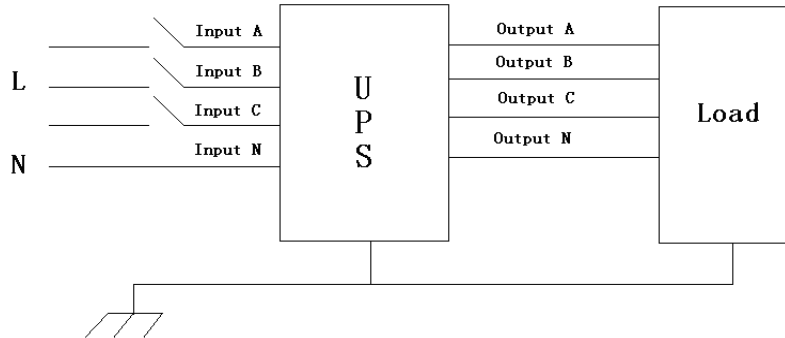

Fig. 5-7 Connection of the UPS and the load



WARNING

If the load equipment is not ready to accept power on the arrival of the commissioning engineer then ensure that the system output cables are safely isolated at their ends.

Connect the safety earth and any necessary bonding earth cables to the copper earth screw located on the floor of the equipment below the power connections. All cabinets in the UPS must be grounded properly (Fig. 5-7).



WARNING

The earthing and neutral bonding arrangement must be in accordance with local and national codes of practice.

5.6 Battery connection

This UPS series adopts positive and negative double battery structure with common terminal, and with totally configurable 30,32,34,36,38,40,42,44,46,48 or 50pcs in series, depend on customer needs and autonomy. By this way it can be monitor battery state and symmetry between both strings. It must be wired neutral battery terminal (BATN) on middle battery element to work properly. The battery sets between the positive terminal (BAT+) and neutral (BATN) are called positive batteries and between neutral (BATN) and negative (BAT-) are called negative ones. (Fig. 5-8)

All 3 wires from battery to UPS must be same section.

Despite of UPS design was made to be power factor (PF 1.0), configured battery number could change output power factor. For 30 battery set in series, output power factor will be as PF 0.8 , for 32/34 battery set PF 0.9 and for 36 to 50 batteries output power factor will be PF 1.0.

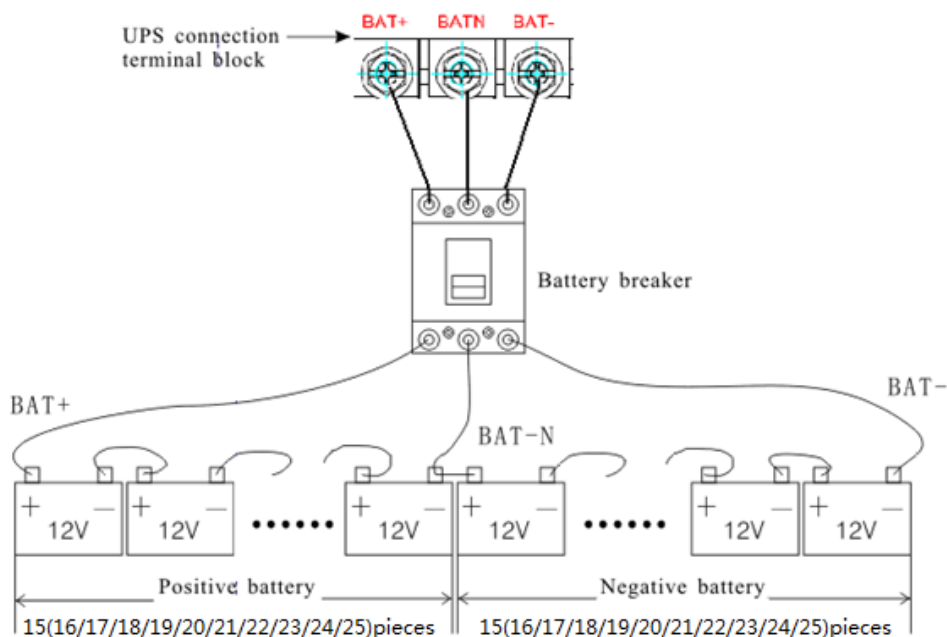

Fig. 5-8 External battery connections for long-run units

As default, all UPS will be set in factory based on customer needs. All related settings can be modified by LCD display menu.

All this adjustments must be done by trained and authorized personal, or contact ZIGOR to receive training or technical assistance.



WARNING

Ensure correct polarity battery string series connection, it means, connect from (+) to (-) terminals between battery blocks.

Don't mix batteries with different capacity or different brands, or even mix up new and old batteries, either.



WARNING

Ensure correct polarity from battery string end connections to the battery breaker, and from the battery breaker to the UPS terminals i.e. (+) to (+) / (-) to (-). Do not close the battery circuit breaker unless authorized by the commissioning engineer.

5.7 UPS parallel Installation

A group of paralleled UPS behaves as one large UPS system but with the advantage of presenting higher reliability. In order to assure that all UPS are equally utilized and comply with relevant wiring rules, please follow the requirements below:

1. All UPS must be of the same rating and be connected to the same bypass source.
2. The outputs of all the UPS must be connected to a common output bus.
3. The length and specification of power cables including the bypass input cables and the UPS output cables should be the same. This facilitates load sharing when operating in bypass mode.

The following sections introduce the installation procedures specified to the parallel system.

5.7.1 Cabinet installation

Connect all the UPS needed to be put into parallel system as below picture (Fig. 5-9).

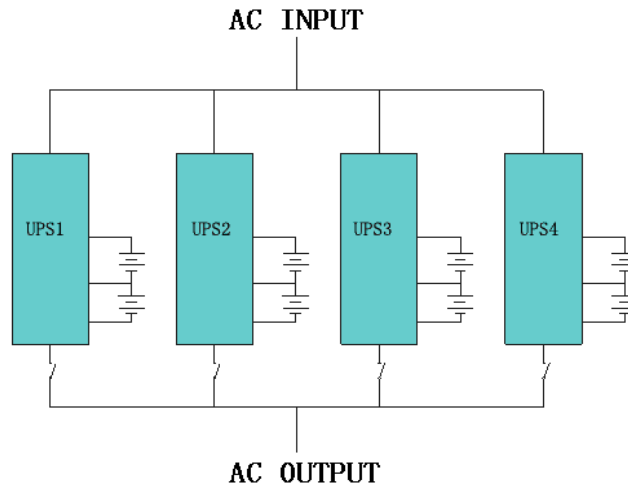

Fig. 5-9 Parallel system

Make sure each UPS input breaker is in “off” position and there is no any output from each UPS connected. Battery groups can be connected separately or in parallel, which means the system itself provides both separate battery and common battery.



WARNING

Make sure the N, A (L1), B (L2), C (L3) lines are correct and same sequence between all UPS, and grounding is well connected.

5.7.2 Parallel cable installation

Shielded and double insulated control cables must be used to interconnect in a ring configuration between UPS units as shown below (Fig. 5-10). The ring configuration ensures high reliability of the control.

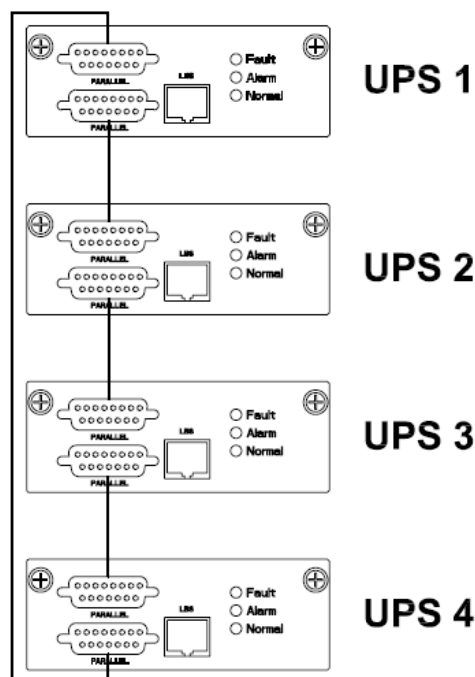

Fig. 5-10 Ring configuration

5.7.3 Parallel setting

To remotely configure UPS to work in parallel mode, it must be done one by one in this sequence:

This parallel configuration can be made by LCD display.

1. Connect the UPS to computer and power on the UPS.
2. Open Muser5000 software, after connecting with the UPS successfully, click “System”->“User Set” (Fig. 5-11).



Fig. 5-11 User set menu location

3. Click “Set” at “User Set” window (Fig. 5-12).

* It could be necessary a Service password to operate. Only authorized personal may change this configuration. Contact ZIGOR for support.

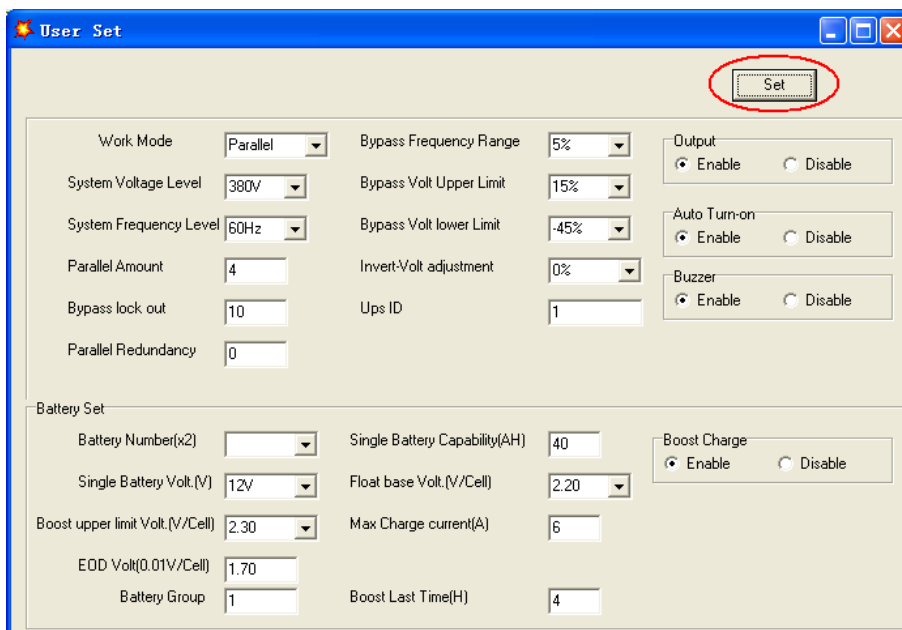

Fig. 5-12 User set window

- At the window of “Data Set”, click “Work Mode”, choose “Parallel” for the value, then click “Set” as shown in below picture (Fig. 5-13). If the UPS sounds a “beep”, that means the setting is correct.

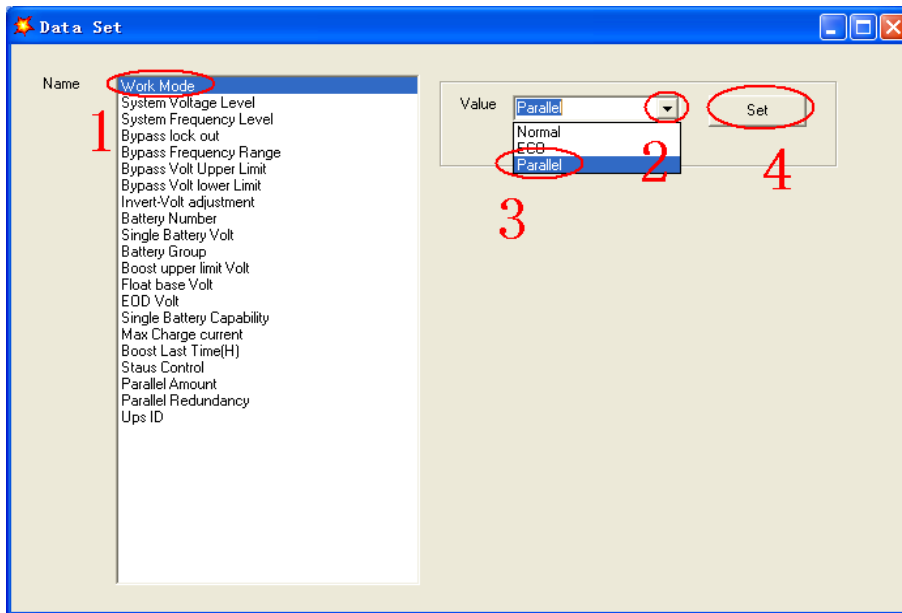

Fig. 5-13 Parallel mode selection

- At the window of “Data Set”, click “Ups ID”, write a value for the parallel UPS ID at the right side, such as “1”, then click “Set” as shown in below picture (Fig. 5-14). If the UPS sounds a “beep”, that means the setting is correct.

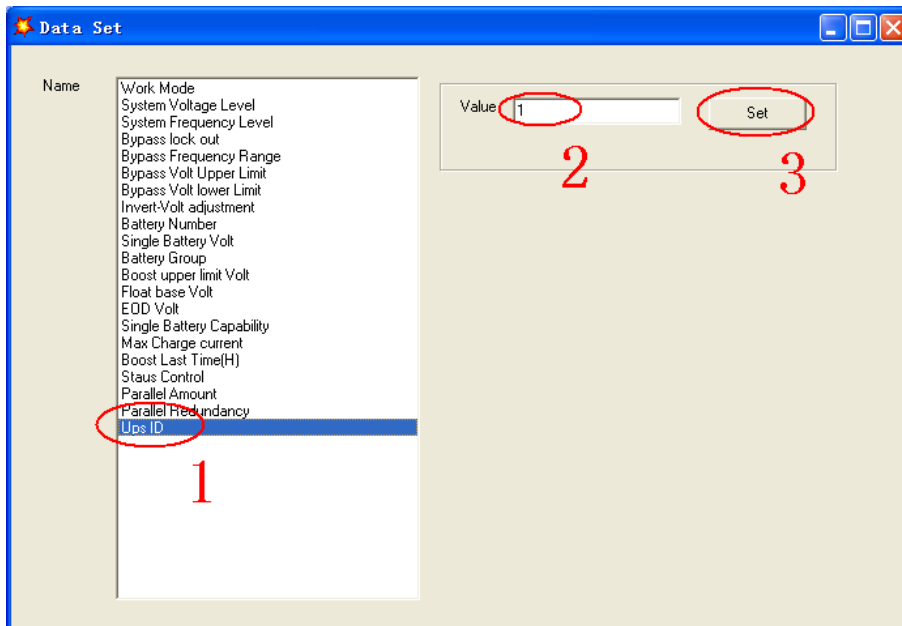

Fig. 5-14 Parallel mode value configuration

- After setting each UPS individually to be in parallel, power off all the UPS. Connect all the UPS according to “parallel cable installation”, and then power on all again.
- If all connections are correct, each UPS will show it unique ID on LCD screen.
- Now it can be closed output breakers.



ATTENTION

After changing the parallel system ID, the connection between Muser5000 and equipment might be interrupted. If it occurs, please re-connect in accordance with the instruction described before.



ATTENTION

Parallel cable cannot be connected when setting the parallel parameters.

5.7.4 LBS installation

The LBS system is a module to keep the outputs of two completely independent UPSs synchronized, even if they come from two different power supplies. LBS system contains LCD set, commucation cable and STS device.

5.7.4.1 LCD screen setting

Set every UPS of the systems to be LBS Master or LBS Slave. For instance if the UPS belongs to LBS master system, its LBS setting must be set to Master.

5.7.4.2 LBS cable installation

The two ports of one mesh wire should be plug into RJ45 interface of any one UPS of both master and slave system (Fig. 5-15).

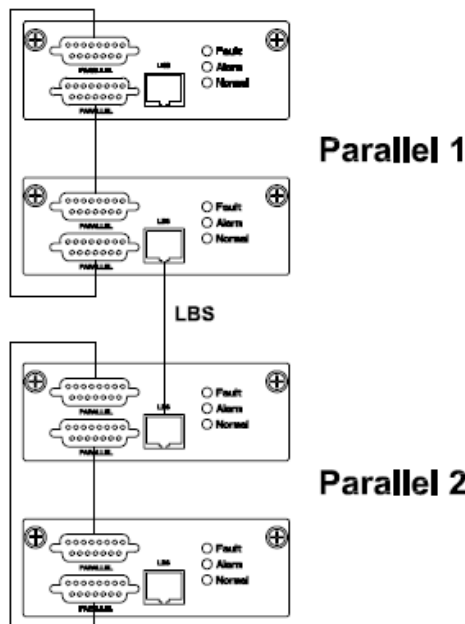

Fig. 5-15 LBS cable installation

5.7.4.3 UPS Installation in LBS mode

The whole system is showed below (Fig. 5-16).

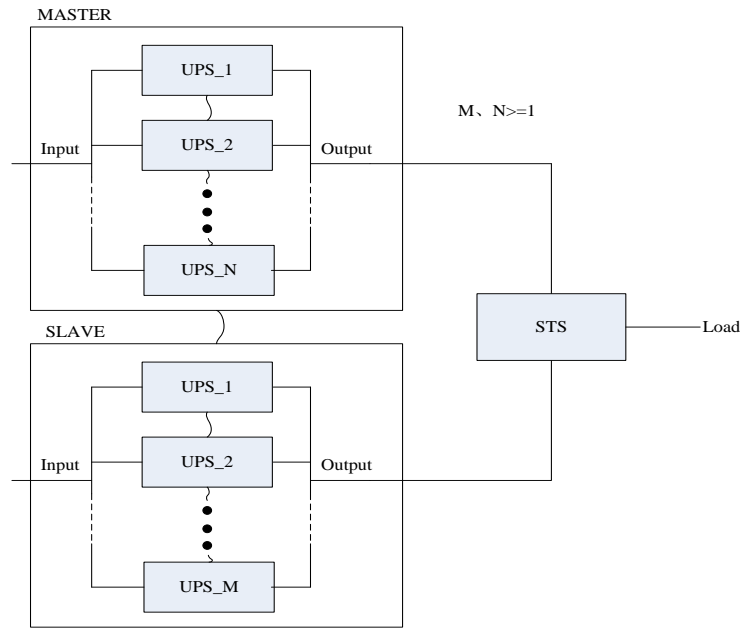

Fig. 5-16 Whole systems installation

5.8 Communications

5.8.1 USB communication port definition

USB communication port definition (Fig. 5-17).

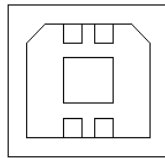

Fig. 5-17 USB port

Connection between PC USB port and UPS USB port (Table 5-7).

PC USB port	UPS USB port	DESCRIPTION
Pin 1	Pin 1	PC : +5V
Pin 2	Pin 2	PC : D+ signal
Pin 3	Pin 3	PC :D- signal
Pin 4	Pin 4	Signal ground

Table 5-7 USB connection

Available function of USB

- Monitor UPS power status.
- Monitor UPS alarm info.
- Monitor UPS running parameters.
- Timing off/on setting.

Communication data format

- Baud rate: 9600bps
- Byte length: 8bit
- End bit: 1bit
- Parity check: none



WARNING

USB and RS232 interface cannot be used at the same time; it can only be used one of them at one time.

5.8.1.1 RS232 communication port definition

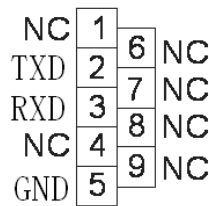

Fig. 5-18 Definition of Male port RS232

Connection between PC RS232 port and UPS RS232 port (Fig. 5-18 and Table 5-8):

PC RS232 PORT	UPS RS232 PORT	
Pin 2	Pin 2	UPS send, PC receive
Pin 3	Pin 3	PC send, UPS receive
Pin 5	Pin 5	ground

Table 5-8 Connection between PC RS232 port and UPS RS232 port

Available function of RS232

- Monitor UPS power status.
- Monitor UPS alarm info.
- Monitor UPS running parameters.
- Timing off/on setting.

RS-232 communication data format

- Baud rate: 9600bps
- Byte length: 8bit
- End bit: 1bit
- Parity check: none



WARNING

USB and RS232 interface cannot be used at the same time, you can only use one of them at one time.

5.8.2 RS485 communication port definition

Definition of port (Fig. 5-19):

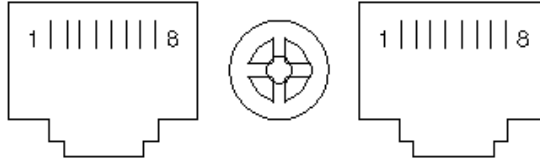

Fig. 5-19 RS485 port

Connection between the Device's RS485 port and UPS RS485 port (Table 5-9).

DEVICE (RJ45)	UPS (RJ45)	DESCRIPTION
Pin 1/5	Pin 1/5	485+ «A»
Pin 2/4	Pin 2/4	485 - «B»
Pin 7	Pin 7	+12 V DC /100mA
Pin 8	Pin 8	GND

Table 5-9 RS485 connections

Available function of RS485

- Monitor UPS power status.
- Monitor UPS alarm info.
- Monitor UPS running parameters.
- Timing off/on setting.
- Battery environment temperature monitoring.
- Charging voltage modulation depending on batteries temperature

Communication data format

- Baud rate: 9600bps
- Byte length: 8bit
- End bit: 1bit
- Parity check: none



WARNING

RS485 port pin7 is 12Vdc / 100mA max.

5.8.3 Optional port definition

Definition of Male port macho (Fig. 5-20):

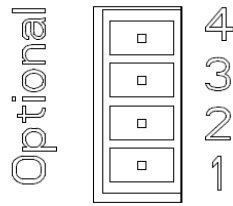

Fig. 5-20 Optional port

Instruction (Table 5-10):

UPS	INSTRUCTION
Pin 1	Normalmente cerrado (NC)
Pin 2	Normalmente abierto (NA)
Pin 3	/
Pin 4	Común

Table 5-10 Optional port instruction

Function 1 description (Optional):

- Drive the bypass breaker when feedback alarm.

Function 2 description (Optional):

- Drive the battery breaker when battery voltage low.

5.8.4 REPO instruction

Connection diagram (Fig. 5-21):

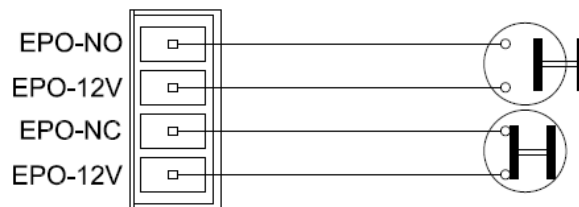

Fig. 5-21 REPO connection

Connection between the button and UPS REPO port. (Table 5-11).

BUTTONS	UPS REPO	DESCRIPTION
Pin 1	Pin 1	EPO-NA
Pin 2	Pin 2	EPO-12 V
Pin 1	Pin 3	EPO-NC
Pin 2	Pin 4	EPO-12 V

Table 5-11 REPO connection

A remote emergency stop switch can be installed in a remote location and connection through simple wires to the REPO connector.

5.9 UPS remote access

- One end of a USB cable connect to the computer, the other end connect to the USB port on the UPS.
- Open the software Muser5000, click “system” button (Fig. 5-22).

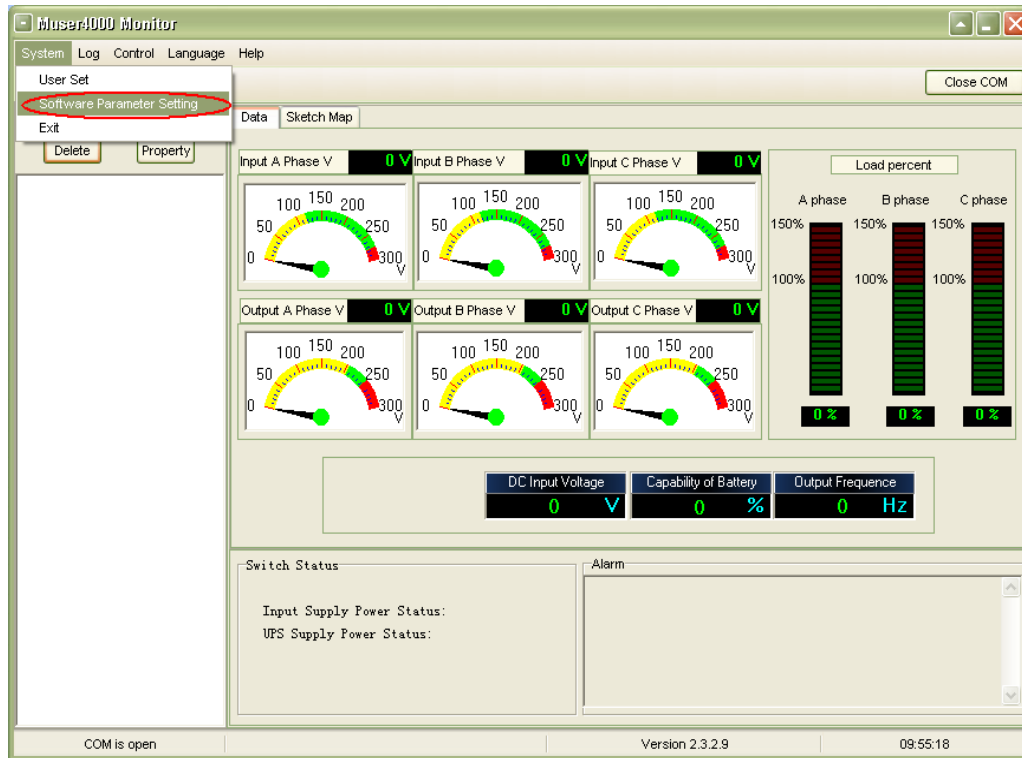

Fig. 5-22 Remote monitorization software

- A window of “Software Parameter Setting” comes out as below (Fig. 5-23), COM choose according to the UPS , baud rate choose 9600, and protocol choose “Modbus”, then save this setting.

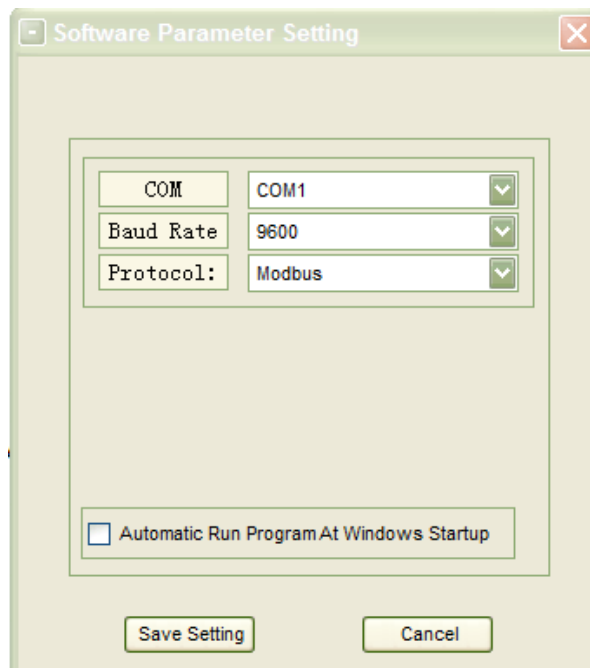

Fig. 5-23 Communication configuration parameters

- On the main page of Muser5000, click the button of “Append”, then goes to a window of “Append equipment” (Fig. 5-24).



Fig. 5-24 Adding an equipment

- Put the UPS name into “Equipment Name”, and UPS’ ID address into “Equipment address” (Fig. 5-25).

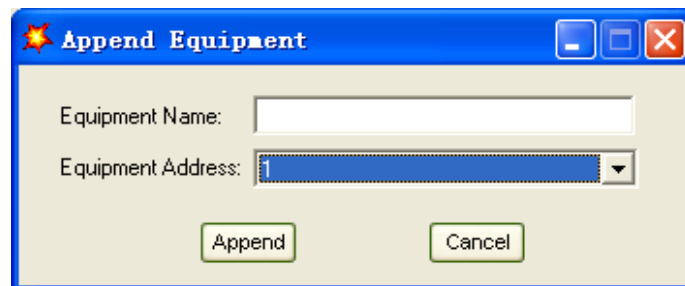

Fig. 5-25 Naming the equipment

- Put the UPS name into “Equipment Name”, and UPS’ ID address into “Equipment address”.



WARNING

Put the UPS name into “Equipment Name”, and UPS’ ID address into “Equipment address”.

6 OPTIONS

6.1 SNMP card

Internal SNMP / Modbus TCP optional card:

- Loosen the 2 torque screws on each side of the card.
- Carefully plugin the card and re-install screws.

The slot called SNMP supports the MEGAtec protocol.

In addition to the features of a standard NetAgent card, NetAgent II has the option to add NetFeeler Lite to detect temperature, humidity, smoke and security sensors. Thus, making NetAgent II a versatile management tool. NetAgent II also supports multiple languages and is setup for web-based auto language detection (Fig. 6-1).

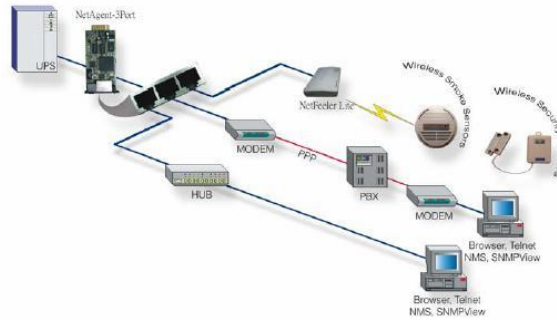

Fig. 6-1 Typical topology of the UPS Network Management

6.2 Relay card

The card is used for providing the interface for UPS peripheral monitoring. The contact signals can reflect UPS running status. The card is connected to peripheral monitoring devices via in-line female terminals to facilitate the effective monitoring of the real-time status of UPS and timely feedback the status to monitor when abnormal situation occurs (such as UPS failure, mains interruption, UPS bypass and etc.). It is installed in the intelligent slot of the UPS.

The relay card includes 6 output ports and one input port. Please refer to the following table for detail (Table 6-1).

Phenomenon	Description	Fault reason
Pin1 & Pin8 OFF	Mains abnormal	Mains frequency or voltage abnormal
Pin2 & Pin8 ON	Battery low	Battery low
Pin3 & Pin8 OFF		
Pin4 & Pin8 OFF	Bypass output	UPS output through bypass
Pin5 & Pin8 OFF	UPS fault	Rectifier fault; INV fault; Over-temperature; short circuit
Pin6 & Pin8 OFF	INV output	UPS inverter output (Online mode)
Pin7 & Pin8 OFF	UPS alarm	Rectifier fault; INV fault; Over-temperature; short circuit
Pin 9 connect 5-12V power Pin 10 GND 0V	Remote OFF	External remote OFF input

Table 6-1 Relay card connections

7 TROUBLESHOOTING

7.1 Malfunctions of ZGR INFLUENCE HP 50 - 200 KVA

ZIGOR recommends that, in case of any anomaly, strange noise or supposed malfunction, the equipment should be shut down and ZIGOR customer service should be contacted.

The system ZGR INFLUENCE HP 50 - 200 KVA has a specific section of active system events, in the Events menu (Table 4-1, Table 4-2 and Table 4-3).

The following table summarizes different anomalous conditions and their possible solution

NO.	PROBLEM	POSSIBLE REASON	SOLUTION
1	Utility is connected but the UPS cannot be powered ON.	Input power supply is not connected; Input voltage low; The input switch of the UPS is not switched on.	Measure if the UPS input voltage/frequency is within the window. Check if UPS input is switched on
2	Utility normal but Utility LED does not light on, and the UPS operates at battery mode	The input breakers of the UPS are not switched on; input cable is not well connected	Switch on the input breaker; Make sure the input cable is well connected.
3	The UPS does not indicate any failure, but output do not have voltage	Output cable does not well connected; Output breaker do not switch on	Make sure the output cable is well connected; Switch on the output breaker.
4	Utility LED is flashing	Utility voltage exceeds UPS input range.	If the UPS operates at battery mode, please pay attention to the remaining backup time needed for your system.
5	Battery LED is flashing but no charge voltage and current	Battery breaker does not switch on, or batteries are damaged, or battery is reversely connected. Battery number and capacity are not set correctly.	Switch on the battery breaker. If batteries are damaged, need to replace whole group batteries, Connect the battery cables correctly; Go to LCD setting of the battery number and capacity, set the correct data.
6	Buzzer beeps every 0.5 seconds and LCD display "output overload"	Overload	Remove some load
7	The UPS only works on bypass mode	The UPS is set to ECO mode, or the transfer times to bypass mode are limited.	Set the UPS working mode to UPS type(non-parallel) or to reset the times of transferring to bypass or re-start the UPS

8	Cannot Black start	Battery switch is not properly closed: Battery fuse is not open: Or Battery low: Battery quantity set wrong; Power breaker in the rear panel not switch ON.	Close the battery switch: Change the fuse: Recharge the battery: Power ON the UPS with AC to set the battery quantity & quantity; Switch on the power breaker.
---	--------------------	---	--

Table 6-1 Trouble shooting

Given the complexity of the equipment, when a serious error occurs and causes the equipment to stop, ZIGOR customer service should be contacted to assist you step-by-step to your resolution by providing the information requested.

Para información más detallada: www.zigor.com
sac@zigor.com

7.2 Recommended spare parts

You can ask ZIGOR for a list of recommended spare parts for the client systems so that a large percentage of malfunctions can be quickly and simply repaired.

8 MAINTENANCE

You can ask for an offer to ZIGOR in order to perform a basic maintenance of this equipment, so that it can prolong the life of the system.

In order to guarantee the correct operation of the ZGR INFLUENCE HP 50 - 200 KVA, it is necessary to carry out a number of maintenance tasks. These tasks enable resolving defects before breakdowns occur and to ensure correct operation of active and passive safety devices.

The frequency of maintenance tasks is dependent upon the location and the atmospheric conditions. The air quality (temperature, dust in suspension, etc.) has a great influence on the amount of maintenance work to be done in order to maintain the functionalities of the equipment within an acceptable level of uncertainty. That is, for example, if the air contains a great amount of dust in suspension, the maintenance work must be carried out more frequently than the standard frequency indicated. The recommended maintenance tasks in accordance with frequency are as follows:

- Monthly:
 - Visual control of correct operation:
 - LEDs indicating correct operation.
 - Values within margins.
 - No active event.
 - Control of the event history, in search of sporadic or repetitive failures.
 - Check nothing blocks the ventilation of the front, rear and side panel and the case bottom.
- 6 monthly:
 - Check on the correct ventilation of the location.
 - Cleaning of the equipment's air inlet filters.
 - Removal of foreign bodies both in the air inlet and outlet.
 - Visual verification of the status of connecting wires, rusting, damage to insulation, etc.
- Annually:
 - Cleaning and blowing of electronics.
 - Checking the tightening and condition of the cables, power and signal.
 - Visual checking.
 - Retightening of the connections.
 - Check for colour changes or deformations due to hot spots.
 - Review of hardware (tightening) and wiring (possible rodent involvement or similar).
 - Cleaning control and water filtration of the room where the system is located.
 - Connection of the external AC protections of the equipment (switches, thermal magnets, etc.) and complete controlled start of the equipment.

For some of these maintenance tasks, shutdowns and disconnections must be made.



Incorrect maintenance can render the warranty null and void.

- Fan: Continual working time of fan is 20000 to 40000 hours. It will be shorter as temperature raises. Please check the fan periodically, make sure there is wind blowing out from it.
- UPS status checking:
 - Check to see if there is any fault occurred, fault indicator is on or any alarm there.
 - Please find the cause if the UPS is working in bypass mode.

- If the UPS is working in battery mode, make sure it is normal; on the contrary, please find out the root cause, such as Utility Failure or self-check of battery.

The rest of the installation must also be maintained adequately. The maintenance tasks to be carried out shall depend on the different elements that make up the installation, emergency generator and cabling. The battery requires special attention.

8.1 Battery maintenance



Efficient maintenance lengthens the service life of batteries and ensures that the unit operates correctly.

Placing the batteries correctly so that all their elements can be easily reached facilitates maintenance. Maintenance consists of checking the following aspects:

- Cleanliness: The elements, their connections and supports must be kept clean and dry. It is recommended to protect the terminals and metal connections with diluted vaseline. Do not use cleaning products containing solvents and/or harmful substances for cleaning elements with plastic containers.
- Connections and terminals: Check the tightness of nuts on the poles of elements as well as the tightness of the electrical connection with at regular intervals of approximately 12 months.
- Checking voltages: Check the voltages of elements in order to detect any possible anomalies in these.

There are sealed lead acid maintenance free batteries inside this series standard models. Battery life depends on environment temperature and discharge/charge cycles, it will be shortened if temperature raised or deep discharged. Periodical maintenance is required so as to keep battery in good condition.

- 1) The most proper working temperature is 15 to 25 °C.
- 2) Avoid small discharging current. **Don't let UPS work in battery mode continuously for 24 hours.**
- 3) Charge battery for at least 12 hours every 3 months if it is free of operation. If the environment temperature is high, charge it once every 2 months.
- 4) For extended backup models, check and clean the battery connectors periodically.

If backup time has become much less than before, or there is battery fault displayed on the LCD, please contact distributors to confirm whether the batteries are needed to be replaced or not.



WARNING

Before replacing batteries, first please turn off the UPS and break off the mains. Remove your metallic adornment such as finger ring, watch and so on.

When replace batteries, please use the screwdriver with insulating handle. Do not lay the tools or metallic goods on the battery.

Never reverse or short-circuit between the battery anode and cathode.

Do not smoke, light a fire or generate sparks near batteries during recharging as there is a risk of fire and/or explosion.

For cleaning, do not use synthetic material clothes or sponges. Keep batteries clean and dry at all times. Protect them against dirt, dust, metal shavings, etc.

9 TECHNICAL SPECIFICATIONS

Model	ZGR INFLUENCE HP 50 - 200								
Power rate	50 kVA 50 kW	60 kVA 60 kW	80 kVA 80 kW	100 kVA 100 kW	120 kVA 120 kW	150 kVA 150 kW	180 kVA 180 kW	200 kVA 200 kW	
INPUT ELECTRICAL CHARACTERISTICS									
Phases	Three-phase + Neutral + ground (3Ph+N)								
Nominal Input voltage	380 / 400 / 415 Vac								
Input voltage Range	138 ~ 485 Vac								
Frequency	40 Hz / 70 Hz (auto-detect)								
Power factor	≥ 0,99								
Bypass voltage range	220 Vac max.: 10 %, 15 %, 20 % or 25 %, default 25 %								
	230 Vac max.: 10 %, 15 % or 20 %, default +20 %								
	240 Vac max.: +10 % or 15%, default +15 %								
	min.: -20 %, -30 % ó -45 %, default -45 %								
	Frequency synchronize tracing range: ±10 %								
Bypass frequency range	± 1 %, ± 2 %, ± 4 %, ± 5 %, ± 10 %								
Distortion (THDi)	≤ 3 % (100 % non lineal load)								
Icc	10 kA								
Generator input	Support								
OUTPUT ELECTRICAL CHARACTERISTICS									
Phases	Three-phase +N + ground								
Output voltage	380 / 400 / 415 Vac								
Voltage regulation	±1,0 %								
Distortion (THDv)	≤ 2 % at 100 % of lineal load								
	≤ 4 % at 100 % of non-lineal load								
Output frequency	1. Line Mode: synchronize with input; when input frequency >± 10% (±1%/±2%/±4%/±5% optional)								
	2. Battery Mode: 50 / 60 Hz (1 ± 0,02%) Hz								
Crest factor	3:1								
Efficiency	95,5 %								
BATTERY									
Battery voltage	360 Vdc ~ 600 Vdc (30 ~ 50 pcs. Pb 12v)								
	- 36 ~ 50 pcs. output power factor 1.0								
	- 32 ~ 34 pcs. output power factor 0.9								
	- 30 pcs. output power factor 0.8								
Battery current	max. 20 A		max. 40 A			max. 60 A			
COMMUNICATIONS									
Monitorization	TFT 7" colour touch + Software								
Communications	USB, RS232, RS485, parallel, LBS, SNMP (optional) , Dry contact (optional)								

OTHERS									
Protections	Short circuit, overload, over temperature, battery low, fan fault alarm								
Transfer time	0 ms (AC > battery)								
	0 ms (AC > bypass)								
Overload	≤110 % : 60 min / ≤125 % : 10 min / ≤150 % : 1 min							60m / 1m / 1s	
Alarm	overload, utility abnormal, UPS fault, battery low, etc.								
Backfeed	Support								
MECHANICAL AND ENVIRONMENTAL CHARACTERISTICS									
Noise level	< 58 dB	< 60 dB	< 61 dB	< 62 dB	< 63 dB	< 66 dB	< 68 dB	< 68 dB	
Operating temperature	0 °C – 40 °C								
Storage temperature	-25 °C – +55 °C (without battery)								
Humidity range	0 - 95 % (without condensation)								
Altitude	< 1500 m / > 1500 m derating power loss								
Dimensions (WxDxH)	250 x 880 x 875 mm		442 x 850 x 1200 mm			442 x 850 x 1200 mm			
	80 kg	83 kg	144 kg	147 kg	155 kg	190 kg	230 kg	230 kg	
STANDARDS									
Marks	CE								
Directives	EN 62040-1, EN 62040-2, EN 61000-3, EN 62040-3, EN 60950-1, ROHS								

- The technical specifications may be modified without prior notice.
- For any other technical need or modification of existing ones, consult ZIGOR

10 STANDARDS

ZGR INFLUENCE HP 50 - 200 KVA model described in this manual comply with the following European regulations:

- I. LVD Security directive LVD 2014/35/EU about Uninterruptible Power Supply (UPS)
Standard: EN 62040-1: 2008/A1:2013
- II. EMC directive 2014/30/EU about electromagnetic compatibility (EMC)
Standard: EN/IEC 62040-2:2018
- III. Conformity:
UPS Clasification: EN 62040-3:2011



11 WARRANTY

Unless otherwise agreed, ZIGOR guarantees that ZGR INFLUENCE HP 50 - 200 KVA units leave the factory in perfect working order and free of any defects for a period of 12 months to be counted as of the date of sale of the apparatus, shown in the delivery note and/or invoice.

ZIGOR will guarantee to the Buyer, the proper functioning against manufacturing and/or workmanship defects. This Warranty includes, whenever the circumstances of good use on the equipment, replace, repair (workmanship included) or refund the purchase price as paid by the customer within the above specified period according to the type of defect and are only and exclusive remedies guaranteed under this Limited Warranty.

The replacement of spare parts, if required, will be made with other new or repaired parts and the replaced ones will become property of ZIGOR.

Unless otherwise agreed, it's not included any assistance and / or displacement. If demanded by the buyer, he'll be held responsible for it.

The customer will be free of charge provided the cause of equipment failure due to defective material thereof, without being affected by the exclusion of warranty causes described in the next section. In any other circumstances be charged the amount of economic displacement.

The following situations will cancel the guarantee of the product:

- Faults due to improper handling of the product, according to the operating instructions, misuse, default grid or by storm.
- Improper use of the equipment according to the Operating Manual and without respecting the original characteristics of the equipment.
- Installation in a place/ environment that does not meet the requirements indicated in the Operating annual referring to the Installation Conditions.
- When the customer not clearly proves the systematic realization of regular maintenance operations described in the Operating Manual.
- Equipment deterioration due to external agents (water, dirt, animals, etc.)
- Damages caused by accident, theft, fire, inadmissible atmospheric conditions, external agents (animals, insects, etc.) or natural disasters.
- In case of any intervention and/or repair by an unauthorised Technical Service.
- The use of equipment or accessories, not sell and/or installed by ZIGOR or their Authorised Technical Service.
- Environmental Operating Conditions out of range.

When the unit is equipped with lead-acid batteries, it must be considered the following precautions:

Those elements are fully charged before shipment. They can be stored for up 2 years provided that they are charged at minimum intervals of 6 months during their storage.

The installation of elements inside the unit by personnel other than those authorised by ZIGOR, shall render the warranty null and void. ZIGOR will not accept responsibility for the repair of equipment if any of the seals installed for internal checks is broken.

The validity of this guarantee is limited to the proper use of the equipment according to the Operating Manual and while respected the original characteristics of the equipment.

The Spanish Standardisation and Certification Association (AENOR) certifies that the "Quality Assurance " and "Environmental Management Systems" adopted by ZIGOR CORPORACIÓN, S.A. for the design, development, production and after sales service for electronic equipment for the conversion of direct and alternating current as well as electronic projections, communications systems, telemanagement applications and electrical and electronic turnkey projects, is an agreement with the requirements of the Spanish Standards UNE-EN ISO 9001:2015 and UNE-EN ISO 14001:2015 respectively.





Zigor Corporación
Portal de Gamarra 28- 01013
Vitoria-Gasteiz Álava/Spain
+34 945 21 46 00
www.zigor.com

Consulte nuestra web para contactar con la red de delegaciones comerciales
Refer to our website in order to contact the commercial branches network
Veillez consulter notre page web pour contacter nos délégations commerciales
Consulte a nossa web para contatar com a rede de degaçoes comerciais