

ZGR SWIT NG

SWITCHING CHARGER - RECTIFIER



ZGR SWIT NG

modules and equipments provide maximum efficiency with a highly compact design.

The range of ZGR SWIT NG chargers, based on high frequency switching technology, benefits from the advantages inherent in such technology achieving a compact and easy-to-use equipment that can be installed in 19" cabinets.

ZGR SWIT NG units integrate all the functions of a high-performance charger in the same module, such as charge management, battery current limitation, remote alarms, end of discharge, protections, among other functions.

ZGR SWIT NG are offered as independent modules or integrated into complete systems. ZIGOR has developed the ZGR SWIT NG range, a rectifier / charger system that ensures the supply of consumers at all times, both in the presence of the mains and in the absence of it, until the end of the system's battery autonomy.

ZGR SWIT NG SYSTEM



ZGR SWIT NG MODULE



APPLICATIONS



TELECOM



INDUSTRY



RAILWAY
SECTOR



ELECTRICITY
SECTOR

CHARACTERISTICS

- » High efficiency
- » Wide range of customized solutions from 500 to 1000 W in 24/48/110/125V
- » Integrated battery disconnecter
- » Reduced voltage harmonic distortion
- » Low input current distortion
- » Battery temperature compensation *
- » Easy installation, front wiring
- » Ni-Cd or sealed Pb battery management
- » Installation in integrated wall cabinet, module 19" and battery

* Optional

» Control and signalling

- Rectifier defect
- Battery ground leakage *
- Maximum output voltage
- Next end of autonomy
- Presence of mains
- Voltmeter and ammeter *
- Dry contacts for remote signalling

» Protections

- Magnetothermal battery protection
- Overvoltage protection
- Input fuse protection *
- Module over-temperature
- Short-circuit
- Current limitation
- Low Voltage Disconnection (LVD)

ZGR SWIT NG SWITCHING CHARGER - RECTIFIER

FULL SYSTEM WITH BATTERIES

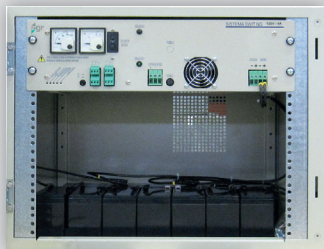

TECHNICAL SPECIFICATIONS

Model	ZGR SWIT NG		
Output voltage	24 Vcc	48 Vcc	110/125 Vcc

INPUT ELECTRICAL CHARACTERISTICS

Nominal voltage	230V ± 15 %		
Nominal frequency	50Hz ± 10 %		
Power factor	0,99 for charge > 60 %		

OUTPUT ELECTRICAL CHARACTERISTICS

Nominal voltage	24 Vcc	48 Vcc	110 / 125 Vcc.
Nominal frequency	20 or 40 A	10 or 20 A	4 or 8 A
Output voltage ripple	< 100 mV rms < 200 mVpp	< 100 mV rms < 200 mVpp	< 100 mV rms < 300 mVpp
Charge current limitation	20A ± 5 %	10A ± 3 %	4A ± 5 %
Short-circuit current	< 20A	< 10A	< 5,5A
Efficiency	> 87 %		

BATTERIES

Num. of elements Pb	12	24	54 or 60
Num. of elements Ni - Cd	18 ÷ 20	36 ÷ 40	86 or 98
Output voltage	18 - 30 Vcc	36 - 60 Vcc	83 - 144 Vcc

MECHANICAL AND ENVIRONMENTAL CHARACTERISTICS

Protections	Battery circuit breaker protection, surge protection, input fuse protection, module overtemperature, short-circuit, current limitation, end of discharge limitation
Operation temperature range	0°C to 50°C
Storage temperature	-40°C to 80°C
Operating altitude	≤ 1000m without power loss
Relative humidity	< 95 % without condensation
Dimensions (HxWxD)	132 x 483 x 278 mm

STANDARDS

Low voltage european directive	CE UNE - EN 50178 (1998)
EMC european directive	UNE - EN 61000-6-2 (2001), UNE - EN 61000-6-4 (2001)

* Special configurations on demand.
* These specifications may change without notice.

INTERNAL ARCHITECTURE

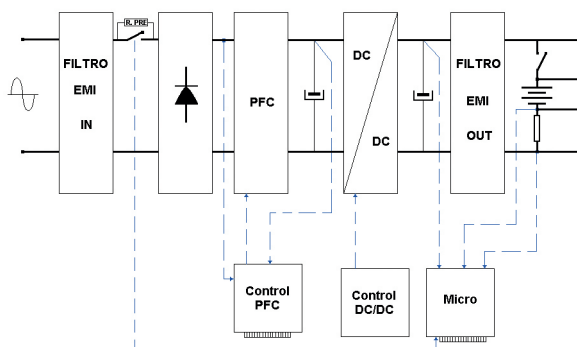

DIMENSIONS



ZGR SWIT NG SWITCHING CHARGER - RECTIFIER